

Automatic Screw Feeder

自動ネジ供給機

OM-26M Type

Operation Manual (Maintenance)

- Read these instructions for the proper use of this machine.
- After having read these instructions, keep them in a convenient place so you or the operator can refer to them whenever necessary.

ATTENTION : www.ohtake-root.co.jp is the only web site associated with our company.
We do not have any branches in China.

各位顾客请注意! : 「www.ohtake-root.co.jp 是敝司唯一的官方网站,
目前, 敝司在中国没有办事处与所谓的中国官网。」

注意! : www.ohtake-root.co.jp が当社唯一の HP アドレスです。
弊社の名を騙る偽サイトにご注意下さい。現在、当社は中国国内に支店はございません。

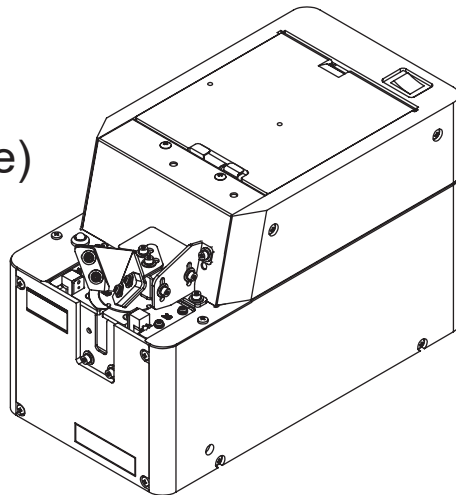

OMM1MAE02dM

Contents

1. OVERVIEW OF THIS MACHINE -----	1	8. EXTERNAL OUTPUT SIGNALS-----	28
2. BEFORE USE -----	1	9. MISCELLANEOUS -----	30
3. OPERATING PRECAUTIONS -----	2	10. TROUBLESHOOTING -----	32
4. NAMES OF MACHINE PARTS -----	5	11. SPECIFICATIONS -----	42
5. ADJUSTMENTS AND CHECKS BEFORE USE-----	7	12. EXTERNAL DIMENSIONS -----	44
6. MAINTENANCE -----	16	13. WARRANTY -----	45
7. PARTS ADJUSTMENTS AND REPLACEMENTS -----	16		

1. OVERVIEW OF THIS MACHINE

Thank you very much for selecting our Automatic Screw Feeder "OM-26M series".

This machine can line up screws (Type M2 - M6) and supplies them one by one to help the efficiency of screw fastening work.

Different sizes of screws can be used by changing the rail and parts of the escaper assembly.

It can be used wherever there is a power source for an AC adapter.

Only steel screws may be used with this machine. Stainless steel or plastic screws cannot be used.

2. BEFORE USE

Please check for the following accessories before operating the machine.

- | | |
|-----------------------------|-----------------------|
| * Instruction Manual 1 copy | * AC Adapter 1 unit |
| * Hexagonal Wrench 1 piece | * Screwdriver 1 piece |
| * Ground Wire 1 piece | |

※ The design, performance and specifications are subject to change without prior notice for the sake of improvement.

3. OPERATING PRECAUTIONS

This manual contains safety alert symbols and signal words to help prevent injuries to the user or damage to property.

◎ Indications



WARNING

This indicates there is a chance of death, serious injury or fire if the instructions are not followed.



CAUTION

This indicates there is a chance of personal injury or damage to property if the instructions are not followed.

◎ Symbols indicating type of danger and preventative measures



Prohibited operation. Never do this!



Do not disassemble, modify or repair.



Do not touch with wet hands.



This indicates to stop operations.



Unplug power supply from wall outlet.













General caution.

Attach the ground wire by loosening the screw near the mark  of the equipment.

















the bottom of the main body

WARNING

-  Do not disassemble the AC adapter as there is a risk of electric shock, fire or malfunction.
-  Do not damage, alter or change the power cord. Do not place heavy objects on the cord.
 Do not pull hard on the cord or twist the cord as it could be damaged, thereby causing a risk of fire or electric shock.
-  Do not handle the AC adapter with wet hands as it could cause an electric shock.
-  When using an outlet with AC100 ~ 240V, don't overload the electrical circuit.
 Do not modify or remodel this machine as this may cause a fire or electric shock.
-  Do not operate this machine near flammable liquids, gasses or materials as there could be a risk of fire or explosion.
-  Stop operating the machine and unplug the AC adapter from the wall outlet when you detect overheating, smoke, a pungent odor or any other unusual condition, as there may be a risk of fire or electric shock. Contact the dealer, from which you purchased the machine and have it examined and repaired.
-  In the case of a thunderstorm, stop operating the machine, turn off the power and unplug the AC adapter from the wall outlet. If there is lightning and thunder nearby, move away from the machine and do not touch it or the AC adapter.
After the thunder stops, and when it is safe to do so, check the machine.
If there is any abnormality, contact your dealer.
-  When performing maintenance, changing parts or when you sense an abnormality in the machine, turn the power off and pull the AC adapter from the wall outlet.
In addition, there are parts that become hot in the circuit board. When performing maintenance around the circuit board, turn off the power for at least 5 minutes before performing work. There is a risk of burns.

CAUTION

-  Use only the AC adapter supplied with this machine otherwise it may result in a fire or electric shock.
-  Do not install this machine in an unstable location otherwise it may fall causing damage or injury.
-  Always operate the machine with the upper cover in place, otherwise it may result in injury.
-  Do not allow any foreign material to enter the machine while in operation.
-  Do not put your fingers into the machine while in operation, otherwise an injury will result.
-  Do not operate this machine in overly humid or dusty conditions.
-  Keep the plug socket clean at all times otherwise it may cause a fire or electric shock.
-  When moving the machine, always disconnect the AC adapter from the wall outlet or it may result in damage to the cord, or cause a fire or electric shock.
-  Turn off the machine and unplug the AC adapter from the wall outlet during closing hours or if the machine will be unused for any extended period of time.
-  When moving the machine, be sure to hold it with both hands and be careful not to drop it. Dropping the machine at your feet may cause injury.
-  Do not operate the machine with tension on the AC adapter cord. Keep the cord loose and untangled.
-  Do not bend, alter or damage the rail. Do not apply any oil. It is recommended that the user clean the rail periodically.
-  Do not use any screw that is out of the specified range nor any screw that is oily or dirty.
-  When picking up screws, do not exert excessive force or shock to the screws.
-  When opening the upper lid, please do not apply excessive force. There is a risk of damage.

4. NAMES OF MACHINE PARTS

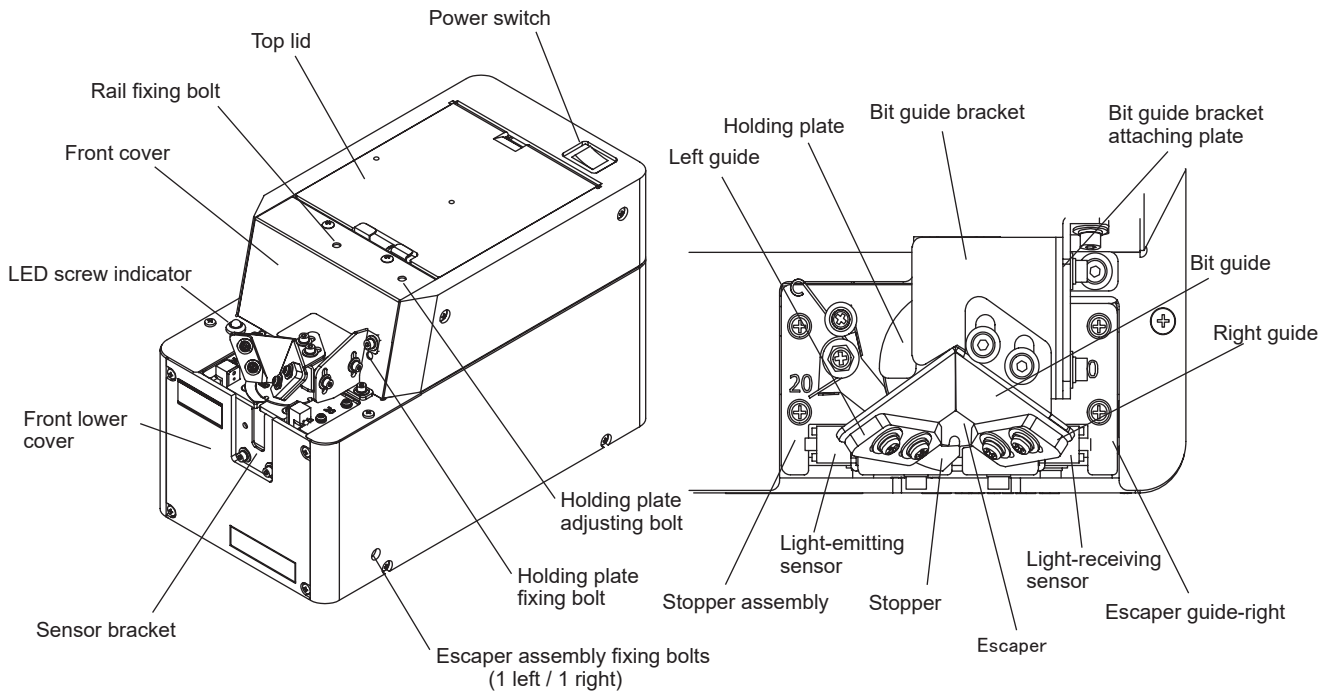

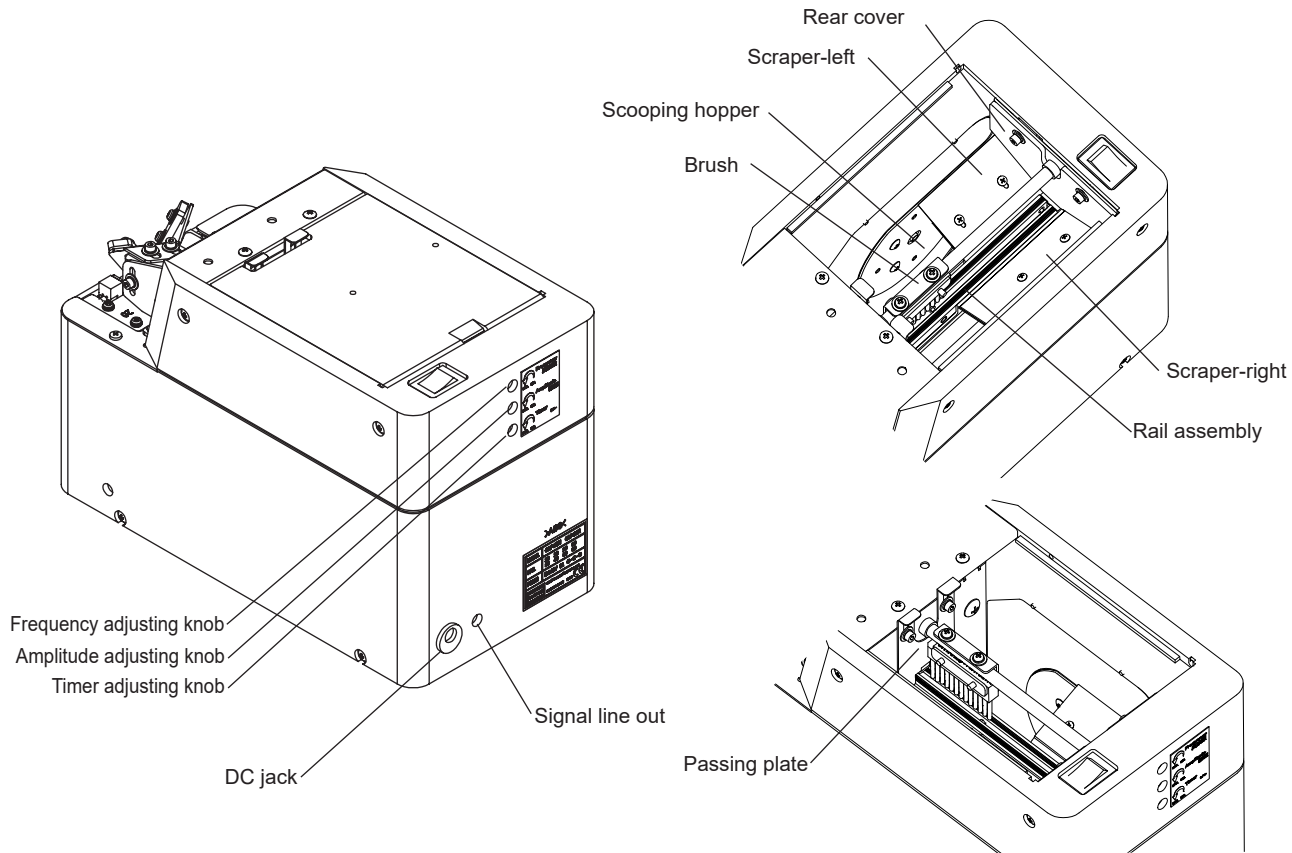

5. ADJUSTMENTS AND CHECKS BEFORE USE

5-1. Checking the model number of the main body

Check if the machine has the parts which match the nominal diameter of the screws to be loaded. Check the model number of the rail, escaper, stopper assembly, escaper guide-right, and passing plate by referring to the following table.

Before delivery, each section of the machine is checked and adjusted with panhead screws matching the nominal diameters of the model ordered. Operate the machine with the screws loaded to check that the pick up is smooth. If the height or or shape of the screw head is different or if the operation is regarded as abnormal, each section must be readjusted.

If this is the case, make the following checks and adjustments:

- Check the screw load amount
- Check and adjust the brush
- Check and adjust the passing plate
- Check and adjust the rail vibration
- Check and adjust the holding plate
- Check and adjust the front and rear sides of the rail
- Check and adjust the timer

Screw feeder series	Screw feeder model	Screw size	Exchange kit No.	Rail model No.	Escaper model No.	Stopper assembly model No.	Escaper guide-right model No.	Passing plate model No.
OM-26M	OM-26M20	φ 2.0	OMM20SET	OMM20	SIE20	SIES20	SIEM20	OM20-30
	OM-26M23	φ 2.3	OMM23SET	OMM23	SIE23	SIES23	SIEM23	
	OM-26M26	φ 2.6	OMM26SET	OMM26	SIE26	SIES26	SIEM26	
	OM-26M30	φ 3.0	OMM30SET	OMM30	SIE30	SIES30	SIEM30	
	OM-26M35	φ 3.5	OMM35SET	OMM35	SIE35	SIES35	SIEM35	OM35-40
	OM-26M40	φ 4.0	OMM40SET	OMM40	SIE40	SIES40	SIEM40	
	OM-26M50	φ 5.0	OMM50SET	OMM50	SIE50	SIES50	SIEM50	
	OM-26M60	φ 6.0	OMM60SET	OMM60	SIE60	SIES60	SIEM60	

If the rail, escaper, stopper assembly, escaper guide-right and passing plate are replaced, screws with a different nominal diameter can be accepted. After these parts are replaced, fine adjusting is required.

The respective adjusting procedures will be described elsewhere. Please read these procedures.

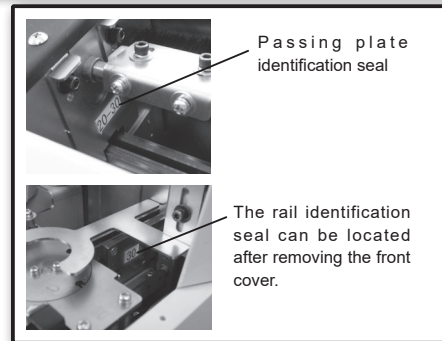
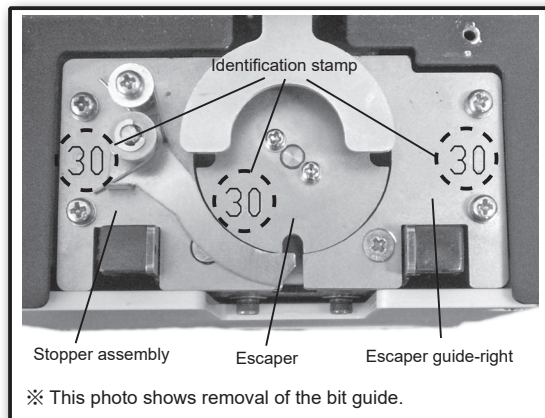

5-2. Basic operations

○Loading the screws

- Turn the power switch ON and OFF so that the brush stops vertically above the rail.
- Open the top cover and load screws on the left and right side of the rail evenly.
- Do not load screws above the surface of the rail.
- Be sure to determine the screw load by observing the machine while it is in operation.

! Screws with a diameter larger than 5 or longer than 20mm, under the head, should not be loaded higher than the rail bottom.

[CAUTION]

- The type and length of screw changes the load capacity so check and adjust the load accordingly.
- Do not overload the hopper with screws otherwise it may cause a malfunction or damage the machine.
- This machine accepts only steel screws. Plastic or stainless screws are not accepted.

○Turning ON the power

- Use only the adapter supplied with this machine to connect it to a wall outlet. When you turn the power on, the switch lamp lights up, the motor rotates and screws are scooped onto the rail.
- The rail vibrates to deliver screws towards the end of the rail, then the escaper rotates to deliver screws to the pick up spot. When the screws come to the stopper, the LED indicator lights up and the escaper stops rotating.

[CAUTION] Use only the AC adapter supplied with this machine otherwise it may cause damage to the machine.

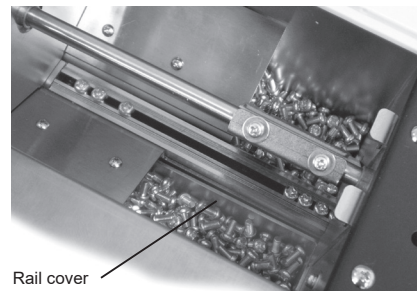

Rail cover

(INDICATION: The maximum screw load must not be over 30mm below the rail-groove surface.)

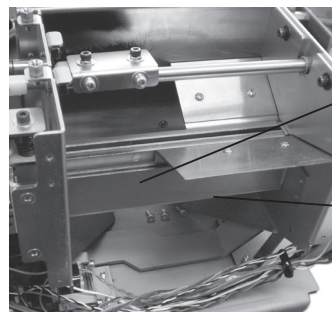

Rail cover

Do not load screws above this point.
(Rail Bottom)

Disassembled state

○Pick uping Screws

- Pick up the screws at the stopper with the electric screw driver.
Use the bit guide to put the screwdriver down vertically into the screwhead's slots, then pull the screwdriver, horizontally, towards you as pick uping the screw.
- When inserting the screwdriver into the screwhead slots, do not use excessive force as it may alter the position of the escaper or cause damage to the machine.
- To insert the screwdriver bit into the screwhead slots properly, it may be necessary to twist the driver slightly.
- Use a driver bit which corresponds with the screw's diameter.

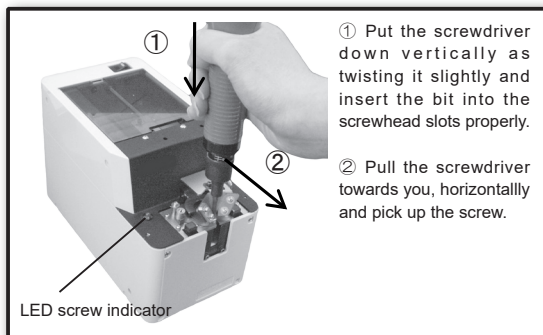

○Action of the escaper

- The escaper rotates 90° clockwise--> stops for about 0.6 seconds --> and rotates again 90° clockwise.

When a screw is caught in the escaper and the notch position is altered, the escaper automatically rotates to the left, as a reference point run, in order to adjust the notch position and then returns to the right rotation.

- This machine continues its operation when no screw is found at the screw pick up spot. The machine continues operating with a screw at the pick up spot but will stop, after a certain lapse of time, if the screw is not picked up. After the screw is picked up, the machine starts operating again. This time lapse can be varied by adjusting the timer.
- When no screw is found at the pick up site after a certain lapse of time, the rail vibration increases.

(The vibration sound, also, increases however, this is not a problem.)

If no screw is still not found at the pick up site, then the machine stops operating. At this time the escaper keeps rotating. When you want to start operation again, turn the power switch OFF and ON again.

○Action of the escaper

Accepting a screw. LED screw indicator is OFF	The screw is carried to the pick up site. LED screw indicator is ON	Pick uping the screw at the pick up site. LED screw indicator is OFF
--	--	---

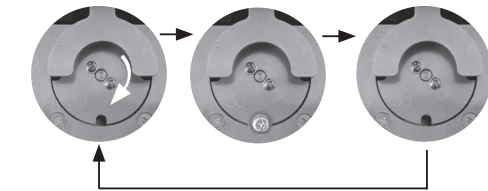

(Reference) The rotation of the escaper, in the opposite direction, is a reference point run of the escaper motor.
The rotation of the escaper, in the opposite direction, occurs when the power is turned on and the starting point of the escaper is not aligned with the reference point of the escaper motor. During regular operation, as in the figure above, the escaper rotates clockwise.

5-3. Adjusting the brush height

- ❗ Turn OFF the power switch before starting replacement and adjustment.

Load the screws into the scooping hopper, turn ON and OFF the power switch so that screws are alligned into the rail groove.

- Turn ON and OFF the power switch in order to set the brush to the left as shown in the figure on the right.
- Move the brush by hand to check that the screws, in the rail groove, are in slight contact with the brush bristles and if needed make the necessary adjustments.
- When the brush height is too high or low, this will have an adverse effect on the screw allignment and transport.
- If any adjustment is necessary, loosen the brush height adjusting bolt to adjust the brush height.
- If the plastic portion, at the front of the brush, comes into contact with the passing plate, loosen the brush assembly mounting screw and move the brush assembly back so there is 0 mm clearance.
- Turn ON the power switch to check that the brush operation is normal.

Turn On and Off the power switch to put the brush bristles in a horizontal position towards the left side.

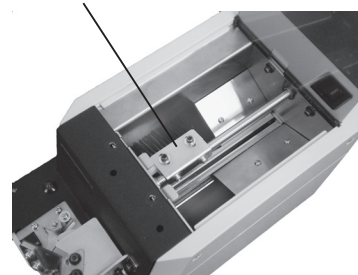

Move the brush by hand to check that the screws, in the rail groove, are in slight contact with the brush bristles and make adjustments if necessary.

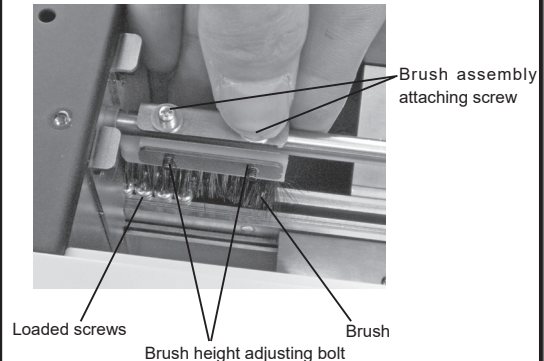

5-4. Checking and adjusting the rail vibration

The amplitude and frequency of the rail vibration can be adjusted.

The vibration has been adjusted at the factory for screws that correspond with the rail.

Put some screws into the rail and turn the power on. If they are delivered smoothly, there is no need for adjustment.

The screw transport feed differs depending on screw type.

For screws with a low transport speed, or screws that easily jump, perform the adjustment according to the following procedure.

Step1: Amplitude VOL Maximum

Step2: Frequency VOL Adjust where screw flows fastest.
(Around the middle)

Step3: If the vibration is too strong, decrease the amplitude.

Use the supplied resin driver. VOL may be damaged.

- If the vibration is adjusted to a too large a value to increase the transport speed, screws may jump from the rail and fall into the machine from the clearance, failing to unload screws normally.

Adjust the vibration to a proper value that matches the loaded screws.

- With the accompanying screwdriver, turn the knob without using excessive force.
- When no screws are scooped onto the rail for a certain period of time, the rail vibration increases. If, still, no screws are scooped on to the rail, the machine stops operating.

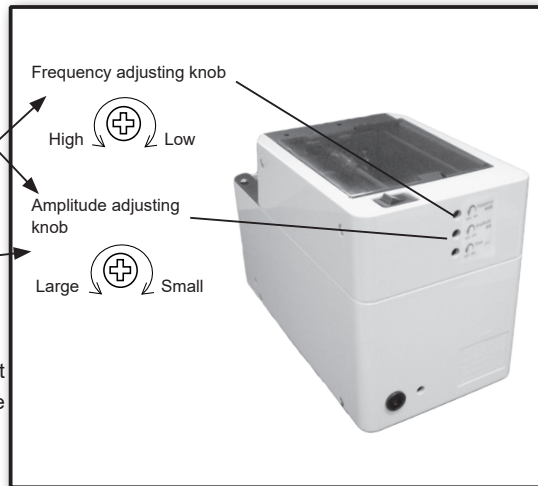

5-5. Check and adjust the front and rear sides of the rail

! Turn OFF the power switch before starting replacement and adjustment.

- If the rail comes into contact with the escaper, or the clearance between the rail and escaper is too large, loosen the rail fixing bolt, hold the rail groove and adjust the rail assembly either backward or forward.

After making an adjustment, be sure to tighten the rail fixing bolt.

- When the rail comes in contact with the escaper, the escaper disk doesn't rotate properly. When the clearance between the rail and the escaper is too large, screws may fall down into the machine.
- After making an adjustment, try making a vibration readjustment by referring to "5-4 Checking and Adjusting the Rail Vibration".

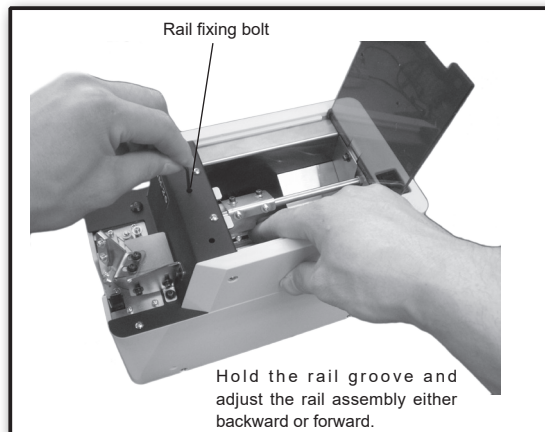

5-6. Check and adjust the rear hopper cover

! Turn OFF the power switch before starting replacement and adjustment.

- Check that the clearance between the rear hopper cover and the rail assembly is about 0.4 mm.
- If the rail hits against the rear hopper cover, the vibration will become weak and the screws will be delivered slowly.
If the rear hopper cover is too high, the slit between the rail and the scraper catches screws easily.
- If adjustment is required, loosen the rear hopper cover attaching bolts and make an adjustment either up or down.

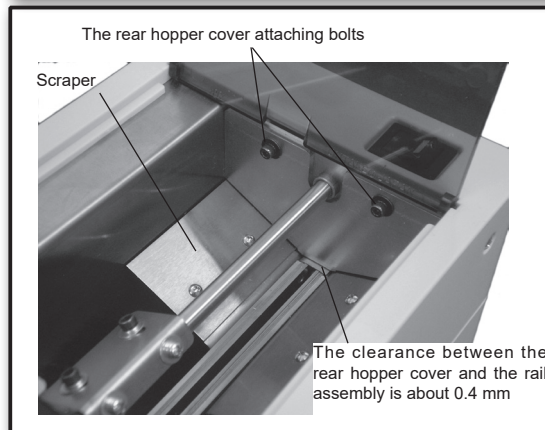

5-7. Check and adjust the passing plate

! Turn OFF the power switch before starting replacement and adjustment.

- Check that the passing plate is adjusted to a height that permits loaded screws to pass just within the limit.
- If the passing plate is too low, screws cannot pass.
- If the passing plate is too high, it will hamper a smooth transport of the screws.
- If adjustment is required, loosen the passing plate attaching bolts and adjust either up or down.

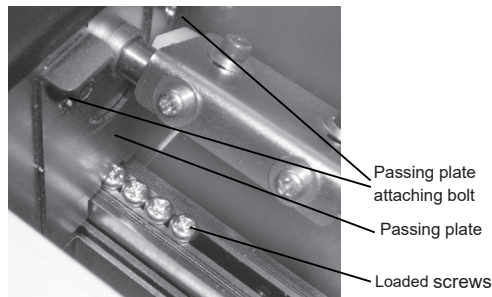

The clearance should be just enough to permit the loaded screws to pass through the passing plate.

5-8. Check and adjust the holding plate

- Check that the clearance between screws in the rail groove and the holding plate is about 0 ~ 1mm.
 - If any adjustment is required, loosen the holding plate attaching screw and turn the holding plate adjusting screw, to move the plate up or down.
 - If there is no clearance, a screw will be blocked. If the clearance is too large, screw piling or screw jump out will occur.
- When the holding plate adjusting screw is turned clockwise, the plate moves down.
- When the adjusting screw is turned counterclockwise, the plate moves up.

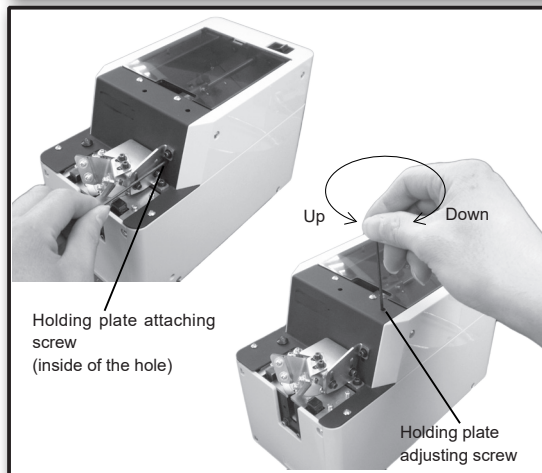

5-9. Check and adjust the timer

The screw transport feed differs depending on screw type.

This machine can make screw unloading smooth through timer adjustment. For screws with a low transport speed, set the timer long. For screws with a high transport speed, set the timer short.

- This machine continues its operation when no screw is found at the screw pick up spot. The machine continues operating with a screw at the pick up spot but will stop, after a certain lapse of time, if the screw is not picked up. This time lapse can be varied by adjusting the timer. After the screw is picked up, the machine starts operating again.
- Check the operation by intercepting the optical axis of the sensor, covering one of the sensors.
- Make an adjustment with the timer adjusting knob (the 3rd hole from the top) at the rear of the machine body (as shown in the figure on the right).
- When the timer knob is turned clockwise, as viewed from the rear side, the time becomes shorter. When the knob is turned counterclockwise, the time becomes longer.(about 1 ~ 6 sec.)

5-10. Check and adjust the scraper

- Check that the clearances, between the scraper right/left and the hopper wall right/left, are around 0.4mm.
- When the scraper makes contact with the hopper wall, the rail vibration becomes weak and the screws are delivered slowly. When the clearance between the scraper and the hopper wall is too large, the screws may be caught easily.
- If any adjustment is required, loosen the scraper attaching screw and move the scraper plate up or down.
- After such adjustments, if deformation on the plate has occurred so that proper clearance and adjustment cannot be achieved, or scratches on the plates had caused trouble in screw movement, please purchase replacement parts for best results.

Left Scraper : TPO11310

Right Scraper: TPO91202

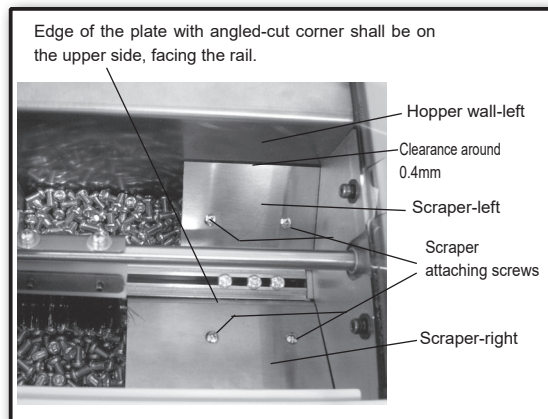
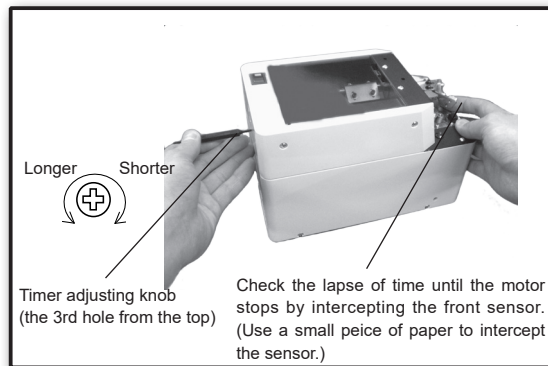

5-11. Checking and adjusting the bit guide

- Adjust the bit guide's height by loosening the attaching bolts.
- Take care that the bit guide does not contact the screw heads.
- Use the screwdriver and Allen wrench that come with this machine. Remember to tighten the bolts and screws after adjustment.
- After adjustment, check that the pick up of screws is smooth.

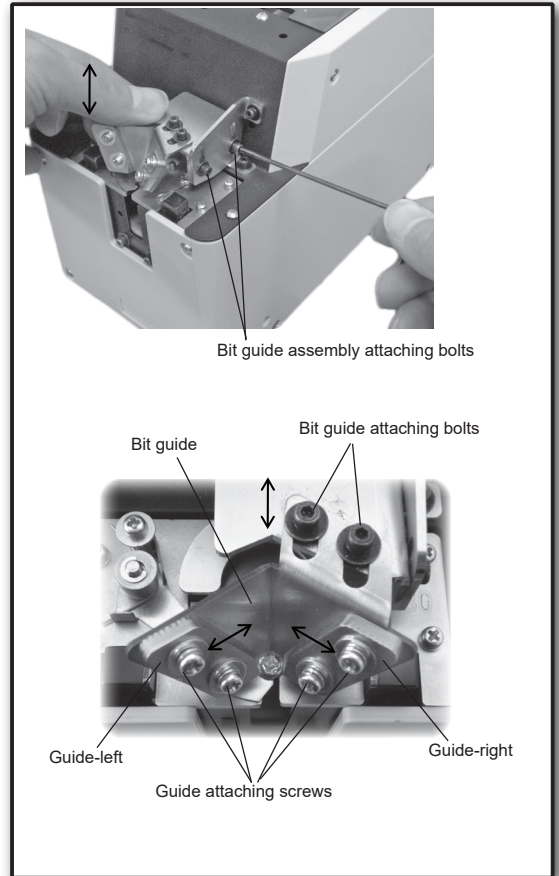

6. MAINTENANCE

A dirty rail groove may interfere with the screw transport speed. Clean the dirty rail with a soft, clean cloth dipped in alcohol. If cleaning is difficult, remove the rail from the machine and clean the rail groove.

Refer to the next section under 『7-1 Replacing the rail assembly』 for replacing.

Before removing the rail from the machine, be sure to turn off the power supply and take the screws out of the hopper. If there is any dirt or a flaw in the rail groove that may cause an impediment in use, we recommend the user to replace the rail.

If iron powder etc. accumulates inside, it may cause vibration to weaken, so remove the cover regularly and clean it with an air blow. For other measures when vibration is weak, refer to 『10 TROUBLESHOOTING』 .

- How to clean the inside

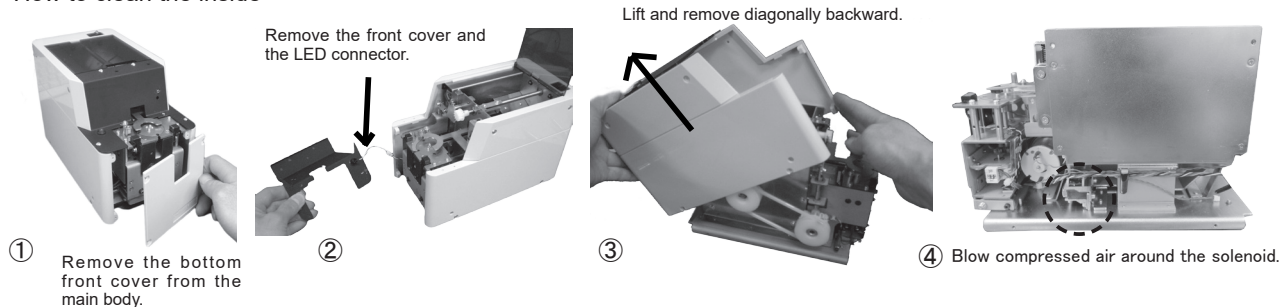

7. PARTS ADJUSTMENTS AND REPLACEMENTS

The brush and main motor are consumable parts.

When using a different diameter of screw, the following items must be replaced: rail, escaper and passing plate. These parts may be ordered separately. The replacing and adjusting procedures are described on the next page.

When replacing any parts, a fine adjustment is required. Make these fine adjustments by reading the corresponding contents carefully. Before replacing any parts, be sure to remove all the screws from the hopper.

7-1. Replacing the rail assembly

! Turn OFF the power switch before starting replacement and adjustment.

Before replacing, remove all the screws from the hopper, the rail, and the escaper.

The rail assembly of this machine can be easily replaced. If there is any dirt or flaw on the rail groove that prevents a smooth operation, we recommend the user clean or replace the rail. Use the passing plate, escaper and rail assembly that correspond to the diameter of the screws to be used.

- ① Remove the bit guide assembly.
- ② Remove the bottom front cover.
- ③ Loosen the escaper assembly screws and pull out the escaper assembly. Insert the accompanying Allen wrench into the left hole on the front top cover and loosen the rail fixing bolt.
- ④ Pull out the rail assembly and replace it with a rail that corresponds with the screws you will be using.

For reassembly, reverse the disassembly procedure. After replacing the rail, adjustments are required. Fix the rail so that it does not contact the escaper and make sure that screws won't fall into the clearance between the escaper and rail.

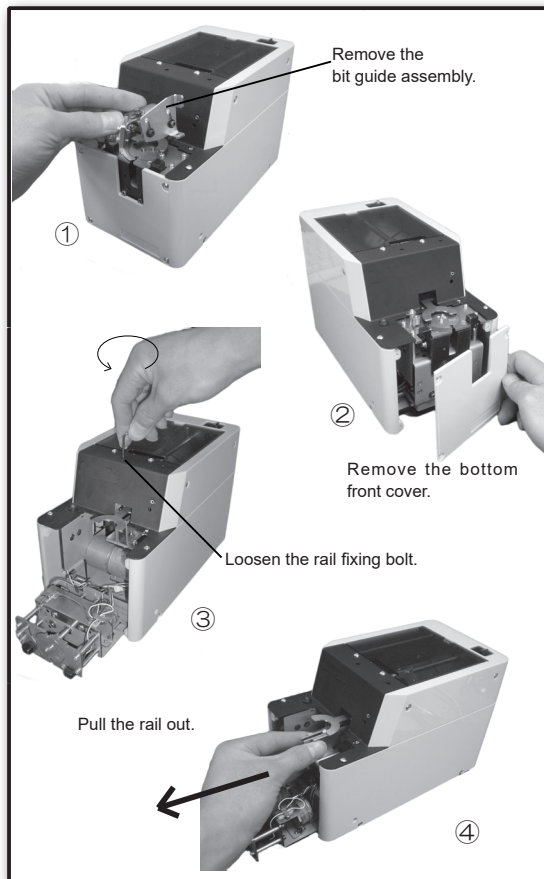

7-2. Replacing and adjustment of the escaper

- ❗ Turn OFF the power switch before replacing.
 - Turn ON the power switch when adjustments are necessary.
- Before replacing, remove all the screws from the hopper, the rail, and the escaper.

When using screws with a different diameter, replace the escaper, the stopper assembly, the escaper guide-right, the rail and the passing plate.

First, remove the bit guide bracket attaching plate and then replace and adjust the parts.

After replacement, be sure to adjust and check the parts in the area of the escaper.

When you remove the escaper attaching screw, please use the driver specified for M2 (bit No.0).

- ① Start by removing, in this order, the escaper guide-right --> escaper --> stopper assembly.

Loosen the attaching screws of the escaper guide-right and the escaper and remove them.

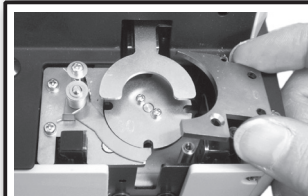
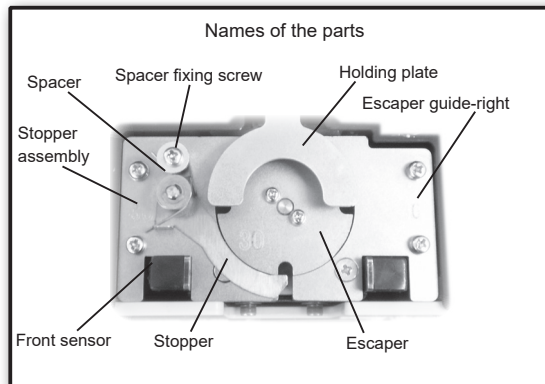

Remove the escaper guide-right.

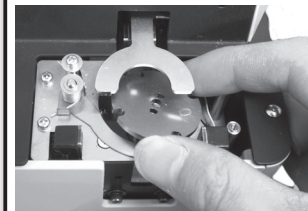

Remove the escaper.

Loosen the spacer fixing screw and remove the spacer.

Remove the screw under the stopper and remove the stopper assembly.

② Attach the escaper guide-right, escaper and stopper assembly that corresponds with the screw's nominal diameter.

First, attach the stopper assembly.
It should be the position as pictured on the right.
(3 screws)

Attach the spacer.
At this time, the stopper should be in the position as pictured on the right.

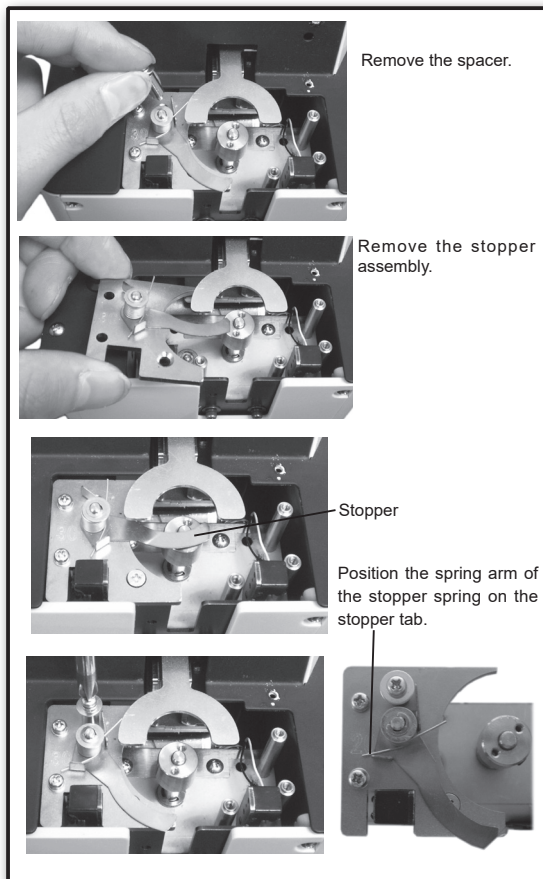

Position one of the spring arms under the plain washer of the spacer screw and the other arm on the stopper tab.

Attach the escaper and the escaper guide-right.

Assemble the escaper loosely as it will need adjusting later. Note that the stopper should not be on the escaper. The stopper should be laying flat against the escaper guide-left. If it is not laying flat, bend it gently by hand to adjust it.

③ Adjust the escaper notch position.

Turn the power switch ON while covering the sensor light axis with a small piece of paper.

When the power is ON, the screw sensor LED lights up and the escaper rotates around, to the starting point. (Reference point run.)

When the escaper stops, loosen the fixing screws and adjust the escaper by hand so that an escaper notch and the rail groove align.

Tighten the escaper fixing screws.

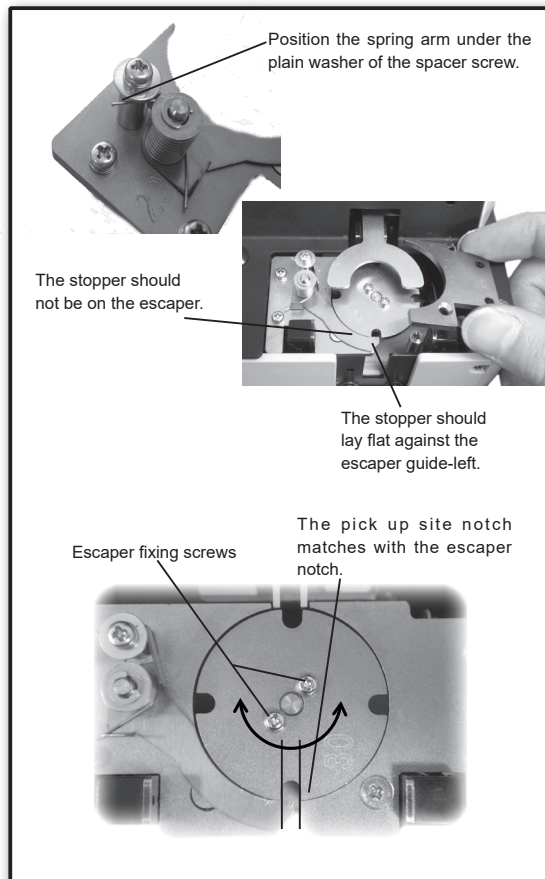

④ Check the position of the parts for smooth delivery of the screws.

! Check that the clearances between the outside edges of the rail and the escaper guide-right and left are almost even.

If they are in contact, the screws cannot be delivered. If there is too much clearance, on either side, screws may fall into the machine.

At this time, make the top surface of the escaper even to or 0.1 ~ 0.5mm lower than the rail surface. If it's too high, a screw won't enter an escaper notch. If it's too low, a screw will not enter a notch properly. If any adjustment is required, remove the cover, loosen the escaper bracket attaching screw and move it up or down, left or right and tighten the screw.

After adjustment, turn the power switch ON in order to make a reference point run and check that an escaper notch and the rail groove align.

After, remove the paper blocking the sensor's optical axis and the escaper will start rotating. Check that all 4 notches of the escaper, in each rotation stop, aligns with the rail groove.

After checking and adjusting each component, do an operational check with screws loaded.

If any abnormality is found, make the said adjustments once again in addition to the rail vibration and front/rear position adjustments. When installing the cover, take care not to catch or pinch the wires.

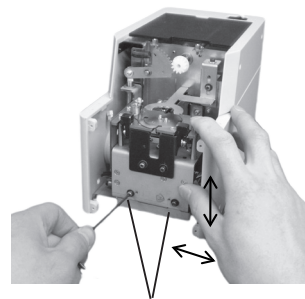

Escaper bracket attaching bolt

There must not be any contact between the rail, the escaper and the escaper guide.

The surface of the escaper should be slightly lower than the surface of the rail.

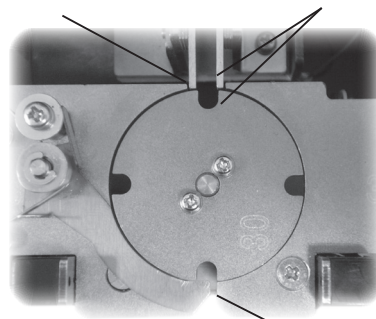

Pick up site notch

7-3. Checking and adjusting the sensor

Usually, there is no need to adjust the sensor as it was done when assembled in the factory.

The following are irregular situations that require adjustment:

- There is no screw at the pick up spot but, the LED is on and the escaper doesn't rotate.
- There's a screw at the pick up spot, but the LED is not on and the escaper rotates. Check when required.

Remove the rear cover of the main unit and measure the voltage level.

Confirm using the test hole on the board.

Connect the negative terminal of the tester to SG and the positive terminal to T3.

When a screw is not at the pick up spot, turn the power ON.

Next loosen the 2 sensor bracket attaching bolts and do the following:

- ① Pull the sensor bracket down and check if the voltage is over 4V and if the sensor light is ON. At this time, the escaper is stopped.
- ② Next, while checking the voltage level, slowly push the sensor bracket up which causes the voltage to decrease. When the voltage is around 0.25V ~ 1.5V tighten the sensor bracket. During this procedure when the voltage is around 2.5V, the LED screw sensor turns OFF and the escaper rotates.

When there is no screw at the pick up spot, the voltage is 0.25V ~ 1.5V and the LED screw indicator is OFF.

When there is a screw at the pick up spot and the voltage is over 3.5V, the LED screw indicator is ON.

This is a general standard. The borderline, whether there is a screw in position or not, is 2.5V.

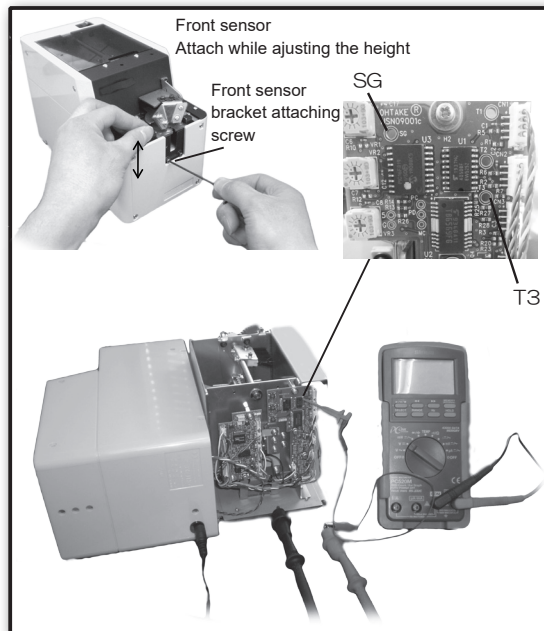

7-4. Replacing the Passing Plate

- ❗ Turn OFF the power switch before starting replacement and adjustment.

Use the passing plate, rail and escaper that correspond with the diameter of the screws to be used.

Remove the passing plate. Do not lose the attached bolts. Using bolts other than those supplied with this machine may result in a malfunction. When installing, use the half-press on both sides of the passing plate as guides.

Refer to page 13 『5-7 Check and adjust the passing plate』 for adjustment.

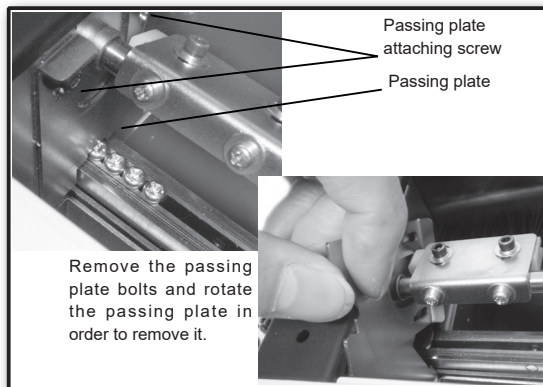

7-5. Replacing and Adjusting the Brush

- ❗ Turn OFF the power switch before starting replacement and adjustment.

If the brush is too worn to sweep screws off of the rail, replace it.

- Turn ON and OFF the power switch in order to set the brush bristles facing to the left and detach the brush assembly.
- The brush assembly can be disassembled as shown in the figure on the right.
- For assembly, reverse the disassembling procedure.
- After completing the assembly, check that the front part of the brush doesn't come in contact with the passing plate. The ideal clearance is 0mm.
- For adjustment, refer to "5-3. Adjusting the brush height".

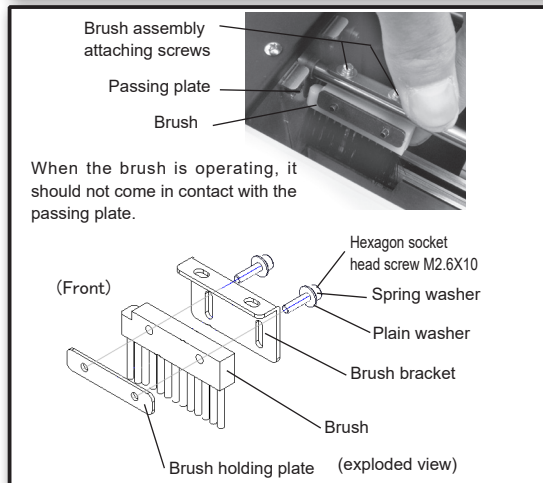

The part number of the brush assembly is TPO00908.

7-6. Replacing the driving belt

! Turn OFF the power switch before starting replacement and adjustment.

If the driving belt is worn, cut or slips while in use, replace it with a new one.

- Turn the power OFF and remove all covers.
- Remove the driving belt from the pulley by using a screwdriver to pry it off.
- When you mount the new belt, start with the driving pulley then the magnetic pulley.
- For assembly, reverse the disassembling procedure.
- After assembly, check that the screws are scooped normally.

[CAUTION]

The driving belt has very strong tension.
Be careful not to pinch your fingers!

The driving belt part number is TEK81011

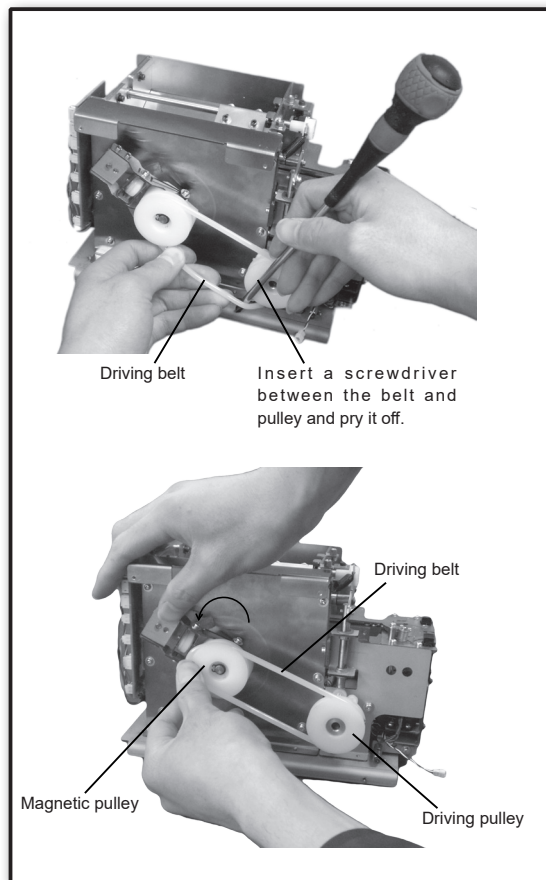

7-7. Replacing the Main Motor

! Turn OFF the power switch before starting replacement and adjustment.

When the motor is damaged, replace it with a new one.

- ① Remove the bottom front cover from the main body.
- ② Remove the LED connector.
- ③ Remove the outside cover screws, lift the main body cover up and diagonally backwards to remove it.
- ④ Remove the driving belt from the pulley by using a screwdriver to pry it off.

[CAUTION]

The driving belt has strong tension.
Take care not to pinch your fingers!

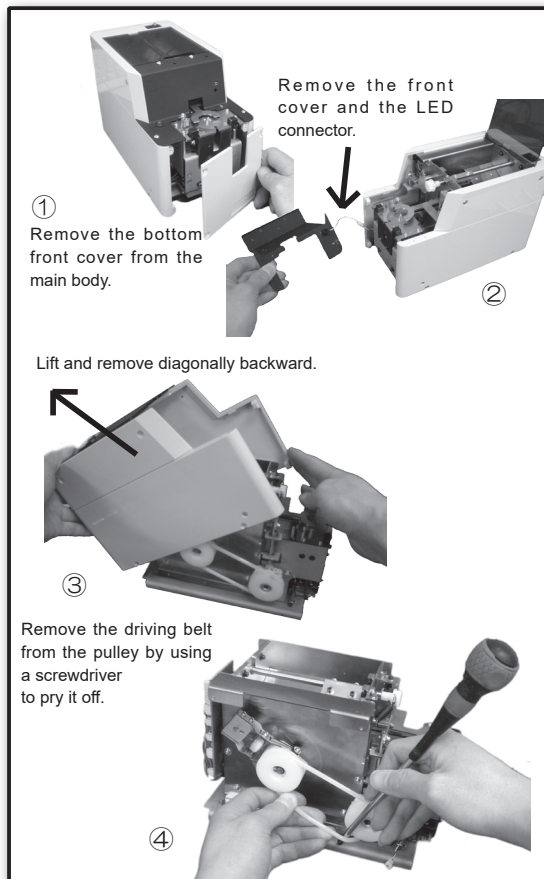

- ⑤ Using the accompanying hex wrench, loosen the 2 hex head bolts from the driving pulley and remove it.
If the bolts are hard to access, rotate the motor pulley with the hex wrench.
- ⑥ Remove the motor attaching screws.
- ⑦ Pull the escaper assembly forward and pull the motor out from the right side of the machine.

Next, remove the motor harness from the clip and remove the connector from the board.

For reassembly, reverse the disassembling procedure.

- ⑧ When attaching the driving pulley, one holding screw should be put in the straight side of the D cut of the motor shaft.

[CAUTION]

Do not use excessive force with the motor wiring in order to avoid wire breakage.

The part number of the main motor is TPO 01002 #17.

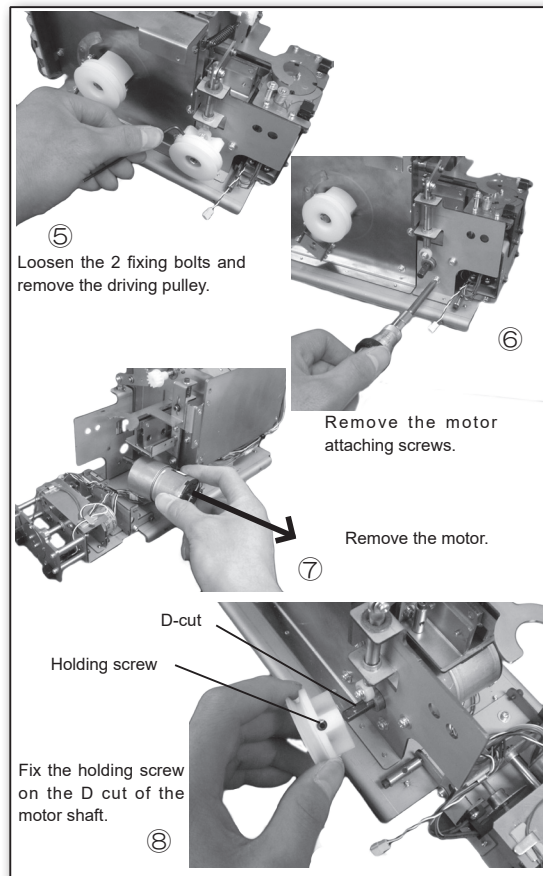

7-8. Replacing the stopper

! Turn OFF the power switch before replacing.

The stopper is a consumable part. When the stopper is worn-off or damaged in shape, replacement is necessary to ensure proper machine operations.

(When stopper is being replaced, the escaper guide does not need to be removed from the machine.)

Part number: E-Stopper TPO-00512

- Release longer end of the stopper spring from the spring holder, and unfasten the spring end nut. When unfastening the end nut, please be cautious that the washer underneath may spring out.
- Disassemble the plain washer, stopper spring, and stopper in order.
- Install the new stopper, stopper spring, and washer in order. Fasten the end nut while holding down the plain washer in place. During this process, please be careful not to allow the spring to become trapped by spring end nut and plain washer.
- When the stopper spring assembly is completely fastened, fix the longer end of the spring onto the spring holder (as shown on right).

Please check if the stopper can move freely, and that the bottom edge of the stopper is completely aligned and parallel with escaper guide.

Please make sure the tip of the stopper does not touch the escaper, as it may interfere with the escaper's rotation.

If the end of the stopper is too close or too far from the escaper, please adjust the bent joint of the stopper where it makes contact with the spring holder, with a pair of long-nose pliers, so that the front of the stopper rests at the proper position.

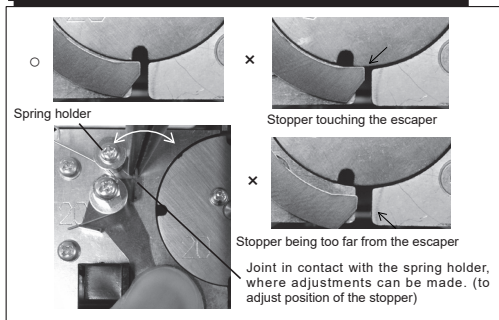
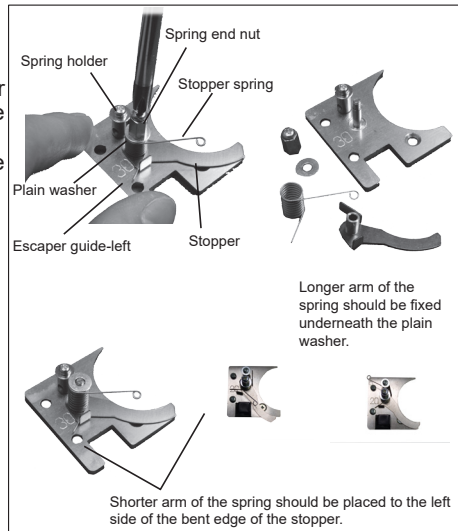

8. EXTERNAL OUTPUT SIGNALS

8 – 1. External Output Signals

This machine can take out the screw extraction signal. Please use it for connection with general purpose sounter etc. Since the signal line is stored inside, when using it please remove the main body cover and pull out the signal line from the outlet hole.

- ① Remove the bottom front cover from the main body.
- ② Remove the LED connector.
- ③ Remove the outside cover screws, lift the main body cover up and diagonally backwards to remove it.
- ④ Pull out the signal line stored inside from the outlet hole of the main body cover.

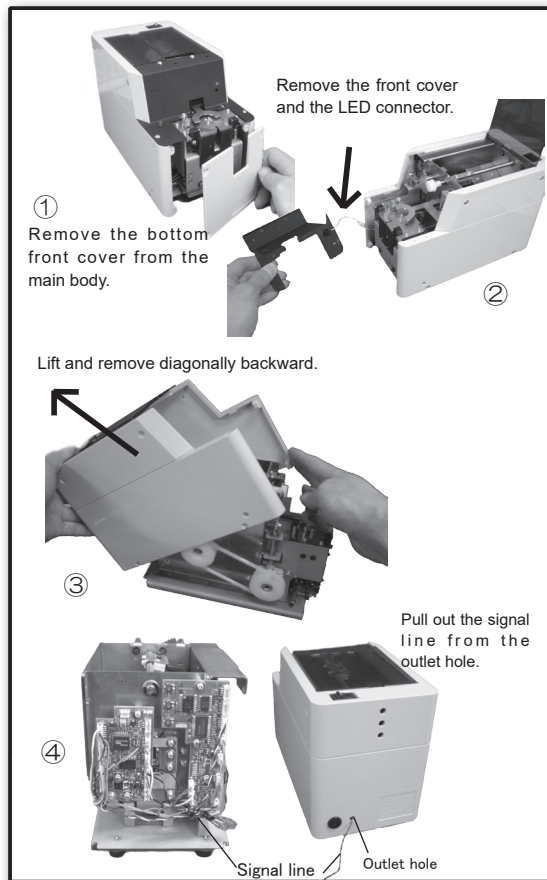

[Function]: Screw present: signal high (ON)
 Incoming current: shall be limited to less than 100mA
 **CAUTION: Additional resistor is required on external circuit for regulating current **

[Capacity]: Max DC current: 100mA
 External supply voltage: 5 ~24VDC
 (Max: 27VDC)

[note]: Please keep the length of output signal wire less than 3m;

* The purple wire functions as signal output high (Collector end), with the gray wire as common (Emitter end)

Purple wire--->Signal line (OFF when no screw is present)
 (On when a screw is present)

Gray wire --->Common line

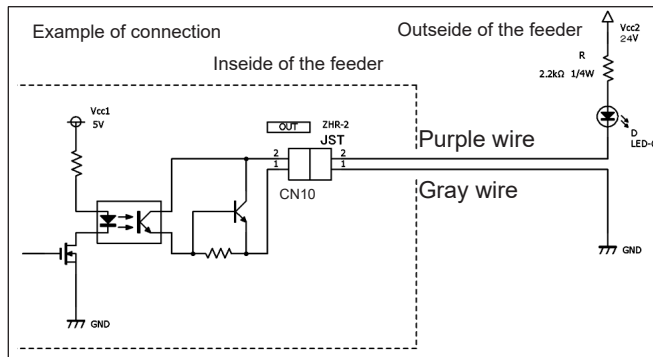

9. MISCELLANEOUS

9 – 1. Screw quantity monitoring sensor (Optional)

There is, as an optional attachment, a sensor which monitors the quantity of screws remaining in the scooping hopper.

With this attachment connected to the signal line, you can set the sensor to monitor the level of screws remaining in the hopper.

○Attachment procedure

- Remove the main body cover.
- Using the accompanying bolts, attach the sensor to the top lid. (2 holes)
- Put the harness through the notch at the back of lid.
- Put the external output signal line, attached to the sensor, into the connector at the top of the board. Put the signal line out through the line-out hole in the cover at the rear.

[Function]: Screw empty: signal high (ON)

Incoming current: shall be limited to less than 100mA

****CAUTION:** Additional resistor is required on external circuit for regulating current **

[Capacity]: Max DC current: 100mA

External supply voltage: 5 ~24VDC (Max: 27VDC)

[note]: Please keep the length of output signal wire less than 3m;

* The Blue wire functions as signal output high (Collector end), with the green wire as common (Emitter end)

- When installing the main body cover, take care not to catch or pinch the harness.
- Next, adjust the screw quantity monitoring sensor by following the instructions in the sensor manual.

Details on how to adjust and use the sensor are in the sensor operating manual. To order, contact your dealer.

[screw quantity monitoring sensor:Part No. TKA09452]

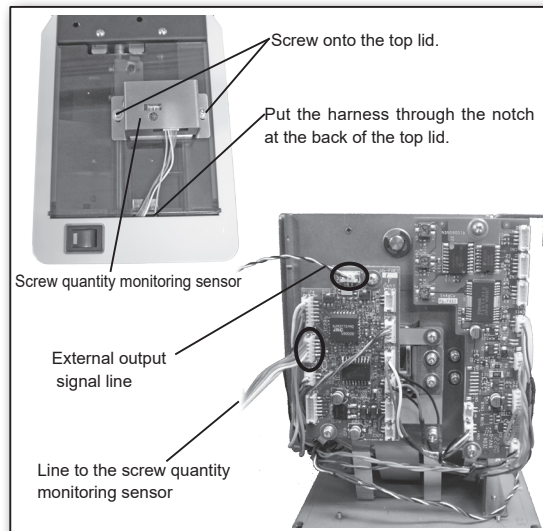

Example of connection

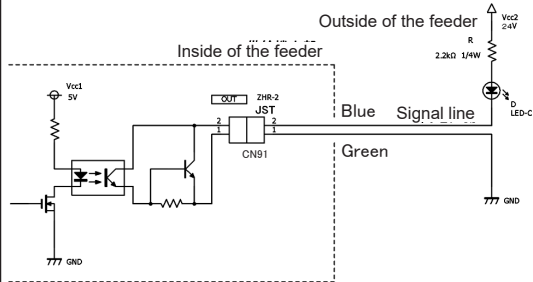

9 – 2. Overload protective circuit

This machine is equipped with an overload protective circuit.

Normally, the driving motor rotates forward to feed screws to the escaper continuously.

However, if there is an overload at the driving section, the driving motor rotates backward for a certain amount of time and then returns to normal rotation.

When the cause for the overload is removed, during the reverse rotation, the driving motor returns to the normal rotation.

If the cause of the overload is not removed, during the reverse rotation, the driving motor repeats the sequence of reverse rotation/normal rotation, reverse rotation/normal rotation to shut off the power to the driving motor.

During this time, the escaper action is not stopped.

When the power to the driving motor is shut off, turn OFF the power switch and remove the cause of the overload.

For example, when too many screws are loaded into the scooping hopper, reduce the quantity of loaded screws to a proper level. If any screw is caught in the transport section, remove it.

After removing the cause of the overload, turn ON the power switch to operate the machine. (Power reset)

10. TROUBLESHOOTING



For safety, always unplug the AC adapter from the wall outlet before making any adjustments.

Trouble	Cause	Corrective measures
The machine does not operate though the power switch is turned ON.	<ul style="list-style-type: none">• Power is not supplied.• A screw hasn't been removed from the pick up spot for a certain amount of time.• Too many screws were loaded into the scooping hopper.• A foreign object (for example: a screw) intruded into the main body.• The AC adapter is faulty.	<ul style="list-style-type: none">• Check the connection of the power supply of the AC power adapter.• Take the screw out from the pick up site.• Adjust the timer setting knob.• Reduce the quantity of screws in the scooping hopper to a proper load level.• Remove the foreign object.• Consult our service section. [Model number UI315-15]
Screws do not flow.	<ul style="list-style-type: none">• Screws with a larger diameter than the specified rail size were loaded or screws with a different diameter were mixed in together.• An insufficient quantity of screws are in the scooping hopper.	<ul style="list-style-type: none">• Use screws with the specified nominal diameter.• Remove the screws with the odd nominal diameter.• Add a proper quantity of screws into the scooping hopper.

Trouble	Cause	Corrective Measure
Screws do not flow.	<ul style="list-style-type: none"> • Screws in an abnormal position in the passing plate cannot be swept away with the brush. • The axis of the screw thread entered the passing plate. • A screw has stopped in an abnormal position while moving on the rail. • The rail does not vibrate. (For example, a screw is caught in the hopper.) 	<ul style="list-style-type: none"> • Adjust the brush. • Adjust the passing plate. If a proper amount of screws are loaded into the scooping hopper, the status may be improved. • Remove the abnormal screw and check and adjust the passing plate. • Remove the screw in the abnormal position. Take care not to damage the rail groove. • Move the holding plate upward to remove the screw. After, adjust the position of the holding plate. • Remove the screw that is obstructing the vibration. • Check the vibration adjustment. • Check that the scraper does not make contact with the hopper wall. If no screw is obstructing the clearance, consult our service section.

Trouble	Cause	Corrective Measure
A screw has fallen into the rail groove.	<ul style="list-style-type: none"> • Screws with a smaller diameter than the specified rail size were loaded. • Screws with a shorter total length than the rail groove width were loaded. 	<ul style="list-style-type: none"> • Use screws with the specified nominal diameter and length. • No corrective measure is available. Consult our service section.
The flow on the screw rail is not working properly.	<ul style="list-style-type: none"> • The clearance between the holding plate and the head of the loaded screw is low. • Screws with a spring washer having one increment smaller than the specified nominal rail size were loaded. • The rail is oily or dirty. • The rail does not vibrate. (A screw is caught in the gap.) • The motor is worn malfunctioning. 	<ul style="list-style-type: none"> • Adjust the holding plate. Adjust the vibration. If, after following the instructions written above, the machine still does not function properly, consult our service section. • Clean the rail. • Remove the screws caught in the clearance. If there is no screw that is caught, consult our service section. • Check that the vibration level is properly adjusted. • Replace the motor. [Part No. : NSB 09182 #05]

Trouble	Cause	Corrective Measure
<p>Screws tend to pass through the passing plate in an abnormal position.</p> <p>The axis of the screw thread tends to enter the passing plate.</p>	<ul style="list-style-type: none"> • The passing plate is not adjusted properly. • Too many screws are in the scooping hopper. 	<ul style="list-style-type: none"> • Adjust the passing plate. • Reduce the quantity of screws to a proper level.
<p>No screw flows to the pick up spot.</p>	<ul style="list-style-type: none"> • Screws are stopped while still on the rail. • Screws cannot be transferred smoothly from the rail to the escaper. 	<ul style="list-style-type: none"> • Adjust the position of the holding plate. • Adjust the distance between the end of the rail and the escaper.
<p>The machine stops its operation suddenly.</p>	<ul style="list-style-type: none"> • The overload protective circuit was activated. • Too many screws are in the scooping hopper. • A screw is caught in the clearance. • A screw at the pick up gap, could not be picked up for an amount of time. 	<ul style="list-style-type: none"> • Turn the machine OFF and then ON again. • Remove the cause of overload. • Remove screws to a proper level. • When the machine stops, even if the screws are at a proper level, consult our service section. • Remove the screw that is caught. • Remove the screw.

Trouble	Cause	Corrective Measure
The scooping operation does not stop though a screw is at the pick up site.	<ul style="list-style-type: none"> • The timer knob is not properly adjusted. 	<ul style="list-style-type: none"> • Readjust the timer knob.
The escaper operation does not stop though a screw is at the pick up site.	<ul style="list-style-type: none"> • The sensor does not detect a screw. 	<ul style="list-style-type: none"> • Readjust the voltage of the sensor.
A screw has fallen into the machine.		<ul style="list-style-type: none"> • Take the cover off and remove the screw.
The noise of the machine has increased.	<ul style="list-style-type: none"> • Adjustments of the vibrational frequency and the amplitude volume are unsuitable. • There is insufficient grease. 	<ul style="list-style-type: none"> • Adjust the vibrational frequency and amplitude volume again. • Apply grease to the transport section. ○ Recommended grease: BR2 Plus , Dow Corning Asia Co. Ltd.

Trouble	Cause	Corrective Measure
<p>The escaper does not rotate when no screws are present, although the indicator light is on.</p>	<ul style="list-style-type: none"> • Undesired objects blocking front screw sensor. • Adjustment of the front screw sensors is unsuitable. 	<ul style="list-style-type: none"> • Make sure there are no debris or other objects present in the sensor brackets. • If the escaper or stopper is damaged or worn-off, parts replacement is recommended. • Adjustment on front screw sensors.
<p>The escaper rotates in the wrong direction.</p>	<ul style="list-style-type: none"> • When the escaper is operating, some alien object is preventing the escaper from rotating smoothly. • Escaper and the escaper guide do not fit together. 	<ul style="list-style-type: none"> • While the screw rotates, please check whether it has hit the holding plate. • If the escaper or escaper guide is damaged or worn off, replacement is recommended.
<p>The escaper continues to rotate in the wrong direction.</p>	<ul style="list-style-type: none"> • The origin sensor may be improperly adjusted. 	<ul style="list-style-type: none"> • Please contact your dealer or our service section.

◀ What to do if the rail does not vibrate or vibration is weak ▶

The possible causes for the above symptoms, which are particularly frequently asked, are listed below. Please check.

※ Since there is no margin in the length of the wiring inside the machine, when removing the main unit cover, please work carefully so as not to cut the wiring by mistake.

If you can not judge the quality of each of the following parts, we recommend that you send a repair request to us without disassembly adjustment.

Cause	Corrective Measure
<p>◎ Damaged substrate (adjustment trimmer). Does vibration (sound) change by turning the frequency / amplitude adjustment trimmer on the back of the main unit (substrate)? If vibration (sound) does not change, the board (trimmer) may be broken.</p>	<p>Replacement of the substrate is necessary.</p>
<p>◎ There is a foreign object in the clearance between the solenoid and the electromagnetic attracting piece. When using screws such as tapping screws that generate a lot of iron powder, iron powder may enter the gap and vibration may weaken.</p>	<p>Please clean the solenoid surroundings with air blow etc.</p>
<p>◎ Inadequate clearance solenoid and electromagnetic adsorption piece. If clearance changes, the vibration may become weak. This also applies when the electromagnetic attracting piece is in contact with the bracket that fixes the solenoid.</p>	<p>The clearance is 0.5 mm. Make sure that the electromagnetic attracting piece is not tilted and adjust the clearance with a shim of 0.5 mm thick. <It is a little difficult adjustment work></p>

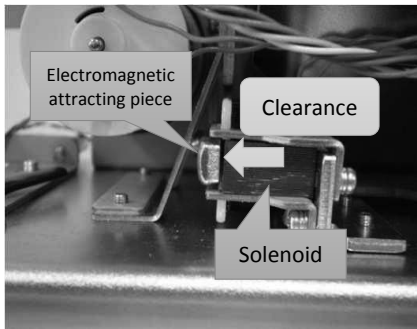

▪ Method of adjusting clearance between solenoid and electromagnet adsorption plate.

- ① Loosen the solenoid fixing screws.
(From the back side)
 - ② Sandwich a 0.5 mm shim in the clearance between the solenoid and the electromagnet attracting plate.
 - ③ Lightly press the solenoid so that the vibration plate does not distort, tighten the solenoid fixing screw.
- When the solenoid is too pressed against the electromagnet suction plate, because it does not take the proper clearance, please be careful.

Cause

© Foreign matter (dropped screw etc.) is in the space between the rail support plate and the motor.
Vibration will be weakened if foreign objects are caught between the vibrating part and the non-vibrating fixed part.

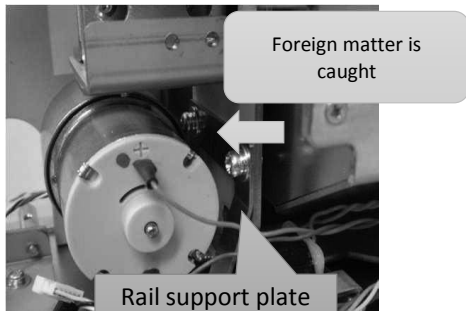

Corrective Measure

Please remove the trapped foreign matter.

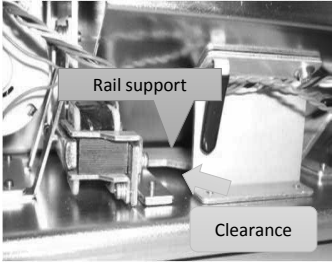
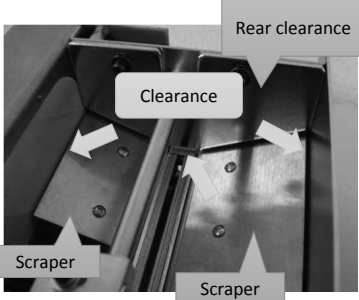
Cause	Corrective Measure
<p>◎ Foreign matter is caught under or around the rail support plate. Vibration will be weakened if foreign objects are caught between the vibrating part and the non-vibrating fixed part.</p> 	<p>Please remove the trapped foreign matter.</p>
<p>◎</p> <ul style="list-style-type: none"> • The scraper is in contact with the wall. • The rear clearance cover is in contact with the rail or scraper. <p>If the vibrating part and the non-vibrating fixed part are in contact, vibration will be weakened.</p> 	<ul style="list-style-type: none"> • Correct the assembling position. <p>Please set the clearance between the scraper and the wall to about 0.4 mm. If the scraper is deformed, replacement is necessary.</p> <ul style="list-style-type: none"> • Please leave clearance of about 0.4 mm for the rear clearance cover.

Cause

Corrective Measure

◎ Passing plate is in contact with rail.
If the passing plate is in contact with the rail, vibration will be weakened.

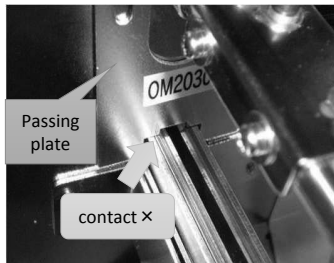

Adjust the position of the passing plate.

◎ • Rail cover and rail pinching plate are in contact.
• Foreign matter is caught in the clearance between the rail cover and the rail clamping plate.
If the vibrating part and the non-vibrating fixed part are in contact, vibration will be weakened.

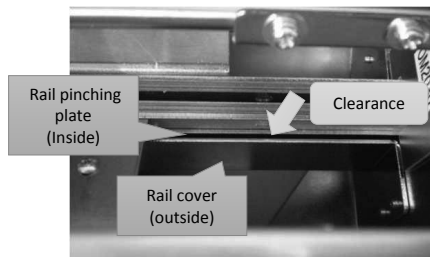

- It is necessary to correct the installation position of the rail cover.
- The clearance between the rail cover and the rail clamping plate should be about 0.4 mm.
- However, please never move the rail clamping plate.
- If foreign matter is caught, please remove it.

11. SPECIFICATIONS

Power AC adapter (switching type)	Input: AC100~240V 50/60Hz
	Output: DC15V 1A
Dimensions	119(W) × 226(D) × 152(H) (mm)
Weight	Approx. 3. 1Kg (including rail)
Screw capacity	Approx. 300cc
Following accessories	Operation Manual 1 copy AC Adapter 1 unit Hexagonal Wrench 1 piece Screwdriver 1 piece Ground wire 1 piece
Installation location	Level stable place
Installation and storage condition	Temperature 0 ~ 40 °C Humidity 10 to 85% (without condensation)
Compliance standards	EMC: 2014/30/EU MD: 2006/42/EC RoHS: 2011/65/EU

[CAUTION]

- This machine accepts only steel screws. Plastic or stainless screws cannot be used.
- Check if the axis diameter of the loaded screw matches the rail groove width.
- Within The range of screw size and length below, there may be instances of unique screw shape or structure not compatible with the feeder unit.
- To use a screw with a different diameter, match it with the corresponding parts mentioned in the table above.
- The rail, escaper, stopper assembly, escaper guide-right, and passing plate are available, separately, for replacement.
- The design, performance and specifications are subject to change, for the sake of improvement, without prior notice.
- The noise of this unit is less than LAeq 70 dB at a distance of 1 m.
- This product complies with EU directive. Please check the EU Declaration of Conformity for compliance standards.





Reference table of the specified screws						Shape of screw head				
Screw size	Screw shaft diameter (φ)	Screw head diameter (φ)	Washer diameter (φ)	Screw head thickness (mm)	Screw shaft length (mm)	Pan head	Pan head			bind
							Sems	Double sems	Washer head	
φ2.0	1.9~2.1	3.0~6.0	3.0~10	0.35~6	3.2~25	○	○	○	○	○
φ2.3	2.2~2.4	3.3~6.0	3.3~10	0.35~6	3.7~25	○	○	○	○	○
φ2.6	2.5~2.7	3.6~6.0	3.6~10	0.35~6	4.2~25	○	○	○	○	○
φ3.0	2.9~3.2	4.0~6.0	4.0~11	0.35~6	4.8~25	○	○	○	○	○
φ3.5	3.4~3.7	4.8~8.0	4.8~11	0.35~6.5	5.6~25	○	○	○	○	○
φ4.0	3.8~4.2	5.4~8.0	5.4~12	0.35~6.5	6.4~25	○	○	○	○	○
φ5.0	4.8~5.2	6.2~10	6.2~12	0.35~7	8.0~25	○	○	○	○	○
φ6.0	5.8~6.2	7.2~11	7.2~12	0.35~7.5	9.6~25	○	○	○	○	○

Note) Compatible with washer thickness 0.35 to 1.6 mm.

Screw feeder series	Screw feeder model	Screw size	Exchange kit No.	Rail model No.	Escaper model No.	Stopper assembly model No.	Escaper guide-right model No.	Passing plate model No.
OM-26M	OM-26M20	φ 2.0	OMM20SET	OMM20	SIE20	SIES20	SIEM20	OM20-30
	OM-26M23	φ 2.3	OMM23SET	OMM23	SIE23	SIES23	SIEM23	
	OM-26M26	φ 2.6	OMM26SET	OMM26	SIE26	SIES26	SIEM26	
	OM-26M30	φ 3.0	OMM30SET	OMM30	SIE30	SIES30	SIEM30	
	OM-26M35	φ 3.5	OMM35SET	OMM35	SIE35	SIES35	SIEM35	OM35-40
	OM-26M40	φ 4.0	OMM40SET	OMM40	SIE40	SIES40	SIEM40	
	OM-26M50	φ 5.0	OMM50SET	OMM50	SIE50	SIES50	SIEM50	OM50
OM-26M60	φ 6.0	OMM60SET	OMM60	SIE60	SIES60	SIEM60	OM60	

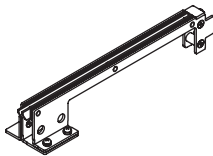
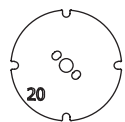
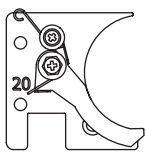
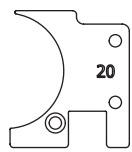
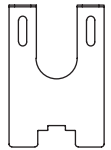
※ -In the Exchange kit ordered, Rail assembly, Escaper, Stopper assembly, Escaper guide-right and Passing plate are included.
-Please contact us by “ ~ SET” type when you need rail.

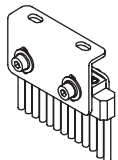
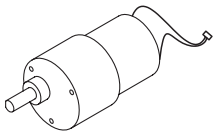
○Replacement parts

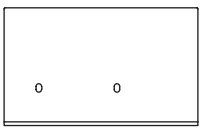
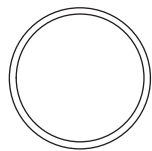
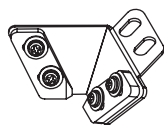
- Rail
 - Escaper
 - Stopper assembly
 - Escaper guide-right
 - Passing plate
 - Stopper TPO00512
- 
- 
- 
- 
- 
- 
-
- Brush assembly TPO00908
 - Main motor (With Harness) TPO01002 #17
 - Left scraper TPO11310
 - Right scraper TPO91202
 - Driving belt TEK81011
 - Bit guide unit TPO00913
- 
- 
- 
- 
- 
- 

1 2. EXTERNAL DIMENSIONS

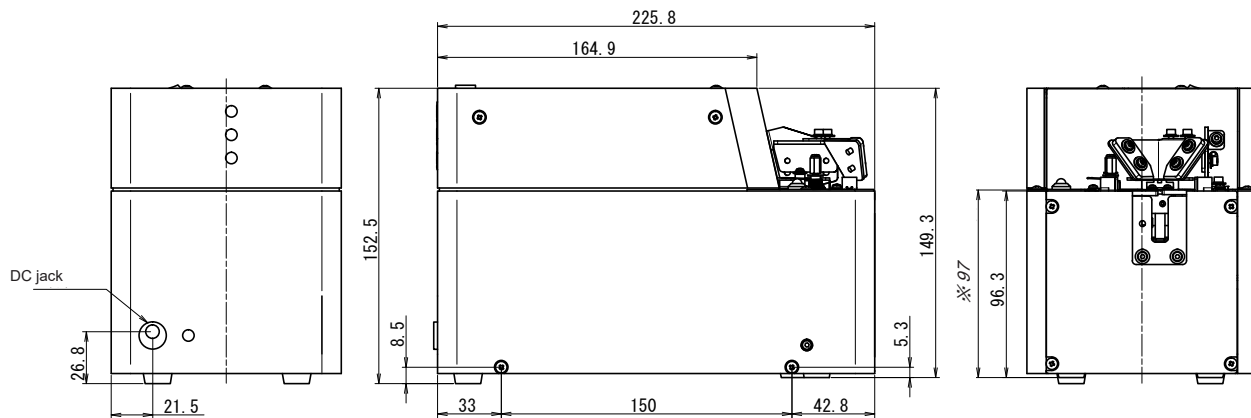
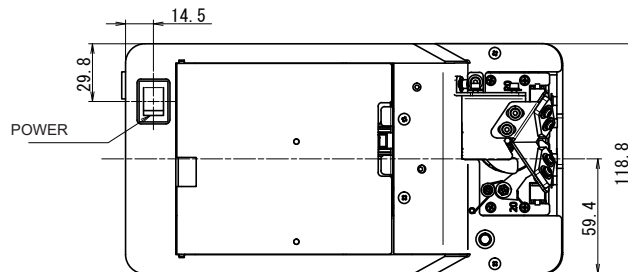

※ Height to top of e scaper

Unit : mm

1 3. WARRANTY

For users within Japan, the effective term of warranty is 6 months after delivery.

Such warranty will not be applicable to purchases or users outside of Japan.

If any troubles should occur, please contact your dealer.

After the warranty period, repair services will be completed.

In the following cases, the purchaser shall pay for parts and labor regardless of the terms of warranty:

- ① Failure due to improper handling.
- ② Failure due to product modification or improper processing.
- ③ Failure due to causes beyond control (for example earthquake or fire).
- ④ Failure attributable to any cause other than this product.
- ⑤ Consumables (brushes, main motor, bit guide, escaper, escaper guide, stopper, driving belt, scraper) and replaceable parts and replacement work expenses.

The repair parts shall be available within 5 years after purchase.

<http://www.ohtake-root.co.jp>

株式会社 大武・ルート工業

岩手県一関市萩荘字金ヶ崎 27 〒 021-0902
Tel +81-191-24-3144
Fax +81-191-24-3145

OHTAKE-ROOT KOGYO CO.,LTD.

27 Kanegasaki Hagisho Ichinoseki
Iwate, 021-0902 JAPAN
Tel +81-191-24-3144
Fax +81-191-24-3145

「Quicher」「OHTAKE」「OHTAKE・ROOT KOGYO」are trademarks or/and registered trademarks of OHTAKE・ROOT KOGYO CO.LTD.
「Quicher(クイッチャー)」「OHTAKE」「OHTAKE・ROOT KOGYO」は、株式会社 大武・ルート工業の商標又は登録商標です。

The specifications and/or design may be altered, without notice, whenever there are changes or improvements.
改良のため、予告なくデザイン、性能、仕様等を変更することがあります。

Photocopying, reproduction or publication, in whole or in part, of this manual, without permission, is strictly prohibited by copyright law.
この取扱説明書の一部または全部の無断転載、複製を禁じます。
© Copyright OHTAKE・ROOT KOGYO CO.,LTD. (as of Apr. 2024)
(2024 年 4 月現在)