

⊕HTAKE 自动螺丝供料机的特点

Features of ⊕HTAKE Automatic Screw / Bolt Feeders

⊕HTAKE 自动螺丝供料机采用水平直进式供料装置。适用对象广泛，可供各种材质和形状的螺丝，满足多样化的使用方式和主体规格的需求。凭借本公司独自开发的装置以及高超的技术，实现了生产线的效率化。

⊕HTAKE's automatic screw feeders make use of a horizontal rail system, which supports a wide range of screw materials and shapes, diverse workstyles, and workpiece dimensions. This unique mechanism and advanced technology can hugely contribute to the efficiency of your production line.



因应螺丝直径和形状变更而切换生产线。帮助提高品质管理和生产效率

Compatible with line changes for adjustments to screw diameter and shape, significantly improving QC and productivity.

这款自动螺丝供料机可使螺丝锁付作业速度获得飞跃性提升。追求使用便利性，采用世界首创的轨道更换方式，可适用不同的螺丝直径以及特殊螺丝。如因工件变更而需使用不同直径的螺丝，只需更换轨道即可。无需更换螺丝供料机主体，可节省设备成本。通过水平直进式供料，可实现高速稳定的螺丝供给。具有出色的通用性和操作性，可帮助提高螺丝锁付作业的效率。

Automatic screw feeders dramatically increase the speed of tightening screws. Through ease of use and employing the world's first swappable rail mechanism, these devices allow you to work with screws of varying diameters and formats. Even if changing a workpiece entails different screw diameters, all you need to do is swap in a new rail. There is no need to replace the feed mechanism itself, reducing equipment costs. The horizontal rail mechanism offers speedy and stable screw feeding, highly versatile design, and ease of use in our OHTAKE automatic screw feeders, driving highly efficient screw-tightening work.



高速、流畅
High-Speed and Smooth



固定位置输出
Fixed-Point Pick Up

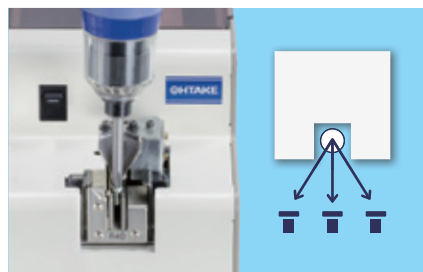

定量输出
Fixed-Quantity Pick Up



⊕ 也适用于带垫片螺丝和特殊螺丝
Supports screws with washers and special formats

通过水平直进方式，也可顺畅供给带垫片螺丝或短螺杆螺丝等特殊螺丝。

The horizontal rail enables the smooth feeding of numerous types of special screws, including those with washers and with short under-head lengths.

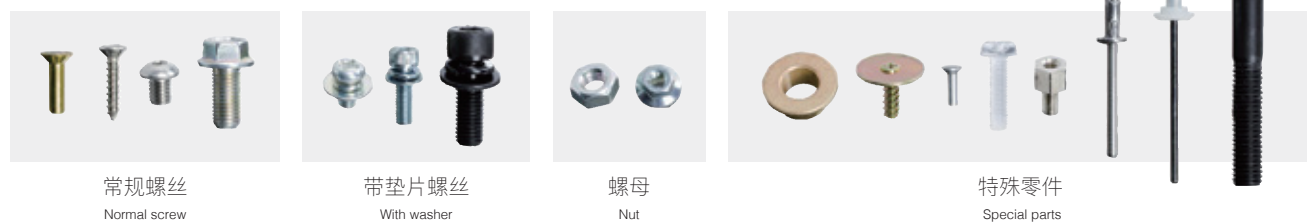

常规螺丝
Normal screw

带垫片螺丝
With washer

螺母
Nut

特殊零件
Special parts

其他主要特点 Other key features

- 使用和操作简便·导入时只需安装即可。之后打开电源即可使用。
- 补充螺丝也非常简单。只要统一投入到螺丝提供口即可。
- 因螺丝直径变更而更换轨道时，仅需1个六角扳手，大约5秒钟即可完成。(NJ/NSB型) 松开轨道固定螺丝，更换轨道，边调整位置，边拧紧固定螺丝即可。
- 一旦螺丝投入过多或堵塞等时，将会自动切断驱动系统的电源，停止运行。
- Easy to handle and operate: Simply install to get up and running. All you have to do is push the power switch.
- Adding screws is a snap. Simply insert in bulk in the scooping chamber.
- It takes only 5 seconds with a single hex wrench to swap the rail and accommodate the screw diameter changes (NJ/NSB type). Simply loosen the rail-tightening screws, swap in a new rail, and adjust the position while tightening the screws back into place.
- In the event that too many screws are inserted or have become clogged, the unit automatically cuts the power to the drive motor and shuts off.



⊕ 采取水平直进方式稳定地排列供给螺丝
The horizontal rail provides a stable, orderly array of screws

与凭借重力的供料方式不同，本产品采取水平直进方式，通过电机振动来输送螺丝。可以解决螺丝堵住的问题，也可以稳定提供带垫片螺丝等。

Unlike gravity-based feed mechanisms, this one uses vibration to convey screws in a horizontal rail, doing away with problems like screw-clogging and allowing stable feeding, even for screws with attached washers.

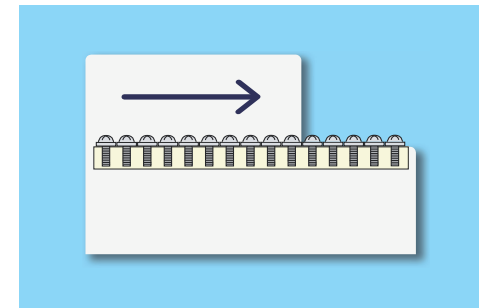

⊕ 螺丝供给速度为平均每秒2个
The average screw feed time is 2 per second

与传统的手工作业相比，可根据使用者的作业条件提高3~5倍的速度。此外，平均每秒可以输出2个螺丝。从而大幅提高了作业效率。

Achieve a three- to fivefold increase in working speed based on traditional manual work. Average screw pick up of 2 per second greatly improves working efficiency.

⊕ 减轻作业负担
Makes work easier

单手即可进行螺丝锁付作业，从而可高效稳定地进行组装作业。

Now you can tighten screws with one hand, improving the stability and efficiency of assembly work.

⊕ 可使用各螺丝刀厂家的标准钻头
Supports standard bits from various screwdriver manufacturers

电动螺丝刀无需安装专用钻头。可直接使用常规标准单钻头。将已磁化的钻头沿着钻头导向器的V槽垂直插入，与螺丝头咬合，向前拉一下即卡入。也支持气吸式类型。

No need to attach a specialized bit to electric screwdrivers. Simply use the standard bits you are accustomed to using. Bring magnetized bits perpendicular with the V-shaped groove of the bit guide, engaging the screw head and allowing it to be caught by simply pulling it close. Supports suction-style screwdrivers.

⊕ 螺丝直径变更时只需更换轨道即可
Accommodate different screw diameters by simply swapping rails

只需更换适合不同螺丝直径的轨道，就能支援各种螺丝。例如，1台NSB型螺丝机可适用8种螺丝直径。

It supports numerous screw types with ease—all you need to do is to swap in the rail for a given screw diameter. For example, NSB models support up to 8 screw diameters in a single device.

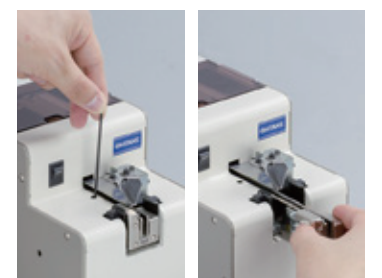

※ 因应机种，有需要更换轨道以外的零件。Some models require exchanging parts in addition to swapping the rail.

[选择机种的步骤]
Selection Process

1 选择用途
Select by use

请先选择用途。根据使用用途在下列一览表
中分别选择“手动用”、“自动用”与“定量取出”。

First, select from "manual," "robotic," or "fixed-quantity pick up."

2 选择机种
Select by workpiece diameter

选择机种。根据所用工件的直径
(●的范围) 选择对应的机种。

Select models based on the diameter of
the workpiece (as indicated by ●)

3 适用(最长)长度
Select by workpiece length (based on the longest ones)

确认工件的长度。工件供给按照螺丝/螺栓的
“螺杆长度”、螺丝料仓按照“全长”进行选择。

Select models based on the length of the workpiece—under-
head length for feeders and total length for screw hoppers.

4 确认材质
Select by workpiece material

确认所用工件的材质。

Select models based on the material
of the workpiece.

请参考产品各页的详细内容。
Find details on the product pages

[机种一览表]
List of Models

1 用途	系列名称	外观	机种名称	2 工件的直径：适用的螺丝 / 螺栓尺寸														3 适用螺丝 / 螺栓 最长螺杆长度	4 可使用的 工件材质	储存容量	取出方式	振动方式	适用的螺丝料仓	特点	登载 页面			
				S0.5 ~S1.0	M1.0	M1.2	M1.4	M1.7	M2.0	M2.3	M2.6	M3.0	M3.5	M4.0	M5.0	M6.0	M8.0											
手动用	NJ		NJ-23						●	●	●	●						18mm	铁 / 非铁制 (材质不限)	150cc	轨道 + 钻头导向器 A	凸轮 (不能调整)	NJ-80 / T-510J / RHP-160J / ※ MHP-80J	-	5			
			NJC-23						●	●	●	●						25mm						-				
			NJL-23						●	●	●	●												18mm	-			
			NJ-45															●						●	●	特殊	-	
			NJC-45															●						●	●	特殊	-	
			NJL-45															●						●	●	特殊	-	
	NSB		NSB		●	●	●	●	●	●	●	●							20mm	铁 / 非铁制 (材质不限)	80cc	轨道 + 钻头导向器 B	凸轮 (螺丝调整)	SR-80 / T-510S / ※ MHP-80S	-	7		
			NSBC		●	●	●	●	●	●	●	●														-		
			NSBI		●	●	●	●	●	●	●	●														-		
			SS		●	●	●	●	●	●	●	●														-		
	SS		SS-12		●	●	●	●	●	●	●									铁 / 非铁制 (材质不限)	40cc	轨道 + 钻头导向器 C	螺旋管 (VOL 调整)	无	-	14		
			SS-23						●	●	●	●														-		
	SSI-M		SSI-12M		●	●	●	●	●	●	●									铁 / 非铁制 (材质不限)	40cc	旋转式排放器 + 钻头导向器 B	螺旋管 (VOL 调整)	无	-	15		
			SSI-23M						●	●	●	●														-		
OM-26M		OM-26M							●	●	●	●	●	●	●	●		25mm	仅限铁制 不能使用不锈钢 (使用磁铁)	300cc	旋转式排放器 + 钻头导向器 A	螺旋管 (VOL 调整)	RHP-160M / ※ MHP-80M	-	11			
		OM-26M (T063)							●	●	●	●	●	●	●	●								-				
LS-HM		LS25-HM															●	25mm	铁 / 非铁制 (材质不限)	1300cc	旋转式排放器 + 钻头导向器 D	螺旋管 (VOL 调整)	无	-	19			
		LS50-HM															●	50mm						-				
自动用	NJR		NJR-23						●	●	●	●						18mm	铁 / 非铁制 (材质不限)	150cc	滑动	凸轮 (不能调整)	NJ-80 / T-510J / RHP-160J / ※ MHP-80J	-	5			
			NJRL-23						●	●	●	●												25mm		-		
			NJR-45															●						●		●	特殊	-
			NJRL-45															●						●		●	特殊	-
			NSR		●	●	●	●	●	●	●	●														20mm	-	
	NSRI		NSRI		●	●	●	●	●	●	●									铁 / 非铁制 (材质不限)	80cc	旋转式排放器	凸轮 (螺丝调整)	SR-80 / T-510S / ※ MHP-80S	-	7		
			SSI-R		●	●	●	●	●	●	●															-		
	SSI-R		SSI-12R		●	●	●	●	●	●	●									铁 / 非铁制 (材质不限)	40cc	旋转式排放器	螺旋管 (VOL 调整)	无	-	15		
			SSI-23R						●	●	●	●														-		
	OM-26R		OM-26R							●	●	●	●	●	●	●	●		25mm	仅限铁制 不能使用不锈钢 (使用磁铁)	300cc	旋转式排放器	螺旋管 (VOL 调整)	RHP-160M / ※ MHP-80M	-	11		
			OM-26R (T063)							●	●	●	●	●	●	●	●								-			
	LS-HR		LS25-HR															●	25mm	铁 / 非铁制 (材质不限)	1300cc	旋转式排放器	螺旋管 (VOL 调整)	无	-	19		
			LS50-HR															●	50mm						-			
	MSF		MSF	●															5mm	铁 / 非铁制 (材质不限)	15cc	旋转式排放器	螺旋管 (VOL 调整)	无	-	13		
定量取出	FM-36		FM-36														●	25mm	铁 / 非铁制 (材质不限)	150cc	手柄	凸轮 (不能调整)	NJ-80F / T-510F / RHP-160F / ※ MHP-80F	-	17			
			FME-36															●						25mm		-		
	LV		LV25														●	25mm	仅限铁制 不能使用不锈钢 (使用磁铁)	1300cc	手柄 其他	螺旋管 (VOL 调整)	无	-	19			
LV50															●	50mm	-											

※ 螺丝料仓：适用的螺丝长度可能与配套的送料机的数值不同，请先确认。 ※ 因螺丝形状可能存在无法使用的情况。
*For the screw hoppers, the compatible length of the screw may differ from that of the feeder it is combined with. Please check the compatibility before use.
*Depending on the shape of the screw, the screw hopper may not be compatible with it.

※MHP-80 只适用铁制(使用磁铁)
*MHP-80 is only compatible with iron screws
(due to the use of a magnet).

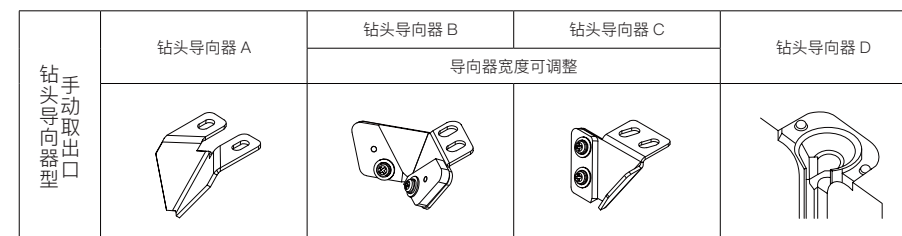
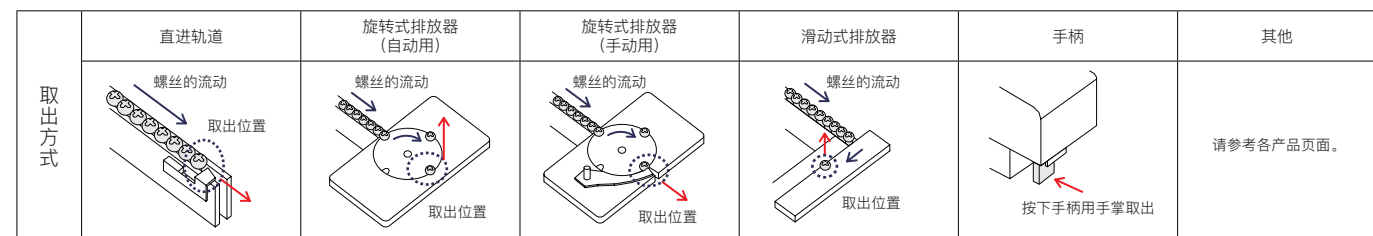

目录
Index

特点
Features

1 页 OHTAKE 自动螺丝送料机的特点
Features of OHTAKE
Automatic Screw / Bolt Feeders

选择机种的步骤与机种一览表
Selecting Models and the Model List

3 页 选择机种的步骤 / 机种一览表
Selection Process / List of Models
4 页 目录
Index

产品系列
Product Pages

5 页 NJ / NJR 系列
全能型螺丝供料机
All-Around Screw Feeder

7 页 NSB / NSR 系列
复合型螺丝供料机
Versatile Screw Feeder

9 页 NSBI / NSRI 系列
复合型螺丝供料机
Versatile Screw Feeder

11 页 OM-26M / OM-26R 系列
高速、大容量铁制螺丝供料机
High-Speed and High-Capacity Iron-Screw Feeder

13 页 MSF 系列
微型螺丝供料机
Micro-Screw Feeder

14 页 SS 系列
薄型螺丝供料机
Slim Screw Feeder

15 页 SSI-M / SSI-R 系列
薄型螺丝供料机
Slim Screw Feeder

17 页 FM 系列
定量计数器 / 外部设定型
螺丝供料机
Fixed Quantity Count /
External Configuration Type Screw Feeder

19 页 LS / LV / LF 系列
大型长螺丝供料机
Large, Longneck Screw Feeder

21 页 BS 系列
气力压送式螺丝供料机
Pneumatic Screw Feeder

23 页 螺丝料仓
Screw Hopper

FAQ

25 页 常见问题
FAQ
关于可通过信号线输出的信号
Signals obtained from signal line

自动螺丝供料机 AC 适配器
插头形状列表
Automatic screw feeder's
AC adapter plug formats

NJ / NJR 系列 全能型螺丝供料机

All-Around Screw Feeder

与 NSB/NSR 系列相比，可支援更大直径的螺丝，大容量更易于使用。

Supports wider screw diameters than the NS/NSR series and has greater capacity, making it even more useful.

适用螺丝直径 M2.0~M5.0	适用螺杆菌长度 最长 18/25mm	容量 约 150cc	非铁制可 Non-ferrous materials supported
---------------------	-----------------------	---------------	---

※ 详细内容参考产品规格书。
For details, please refer to each product's specifications.

手动用 Manual	NJ-23 NJ-45 NJL-23 NJL-45 NJC-23 NJC-45
自动用 Robotic	NJR-23 NJR-45 NJRL-23 NJRL-45



⊕ 支援各螺丝刀厂家的标准钻头

Supports standard bits from various screwdriver manufacturers

- 钻头式螺丝刀 Bit screwdrivers.
- 气吸式螺丝刀 Suction screwdrivers.

⊕ 大容量存放 Large stock

可存放约 150cc Supports a stock of 150cc.

⊕ 支援特殊螺丝 Special screws supported

可放心供给带垫片或带 SW 的螺丝。
Allows you to stably feed SW screws or those with washers.

⊕ 与螺丝料仓组合使用可使机器长时间运行

Long-running operation when combined with screw hopper
配置螺丝料仓，可长时间无人运行。
Use a screw hopper for long-running unmanned operations.

⊕ 螺丝供给流畅 Smooth screw feeding

- 供给螺丝时不会出现机器人动作延迟的现象。
- NJ 型可通过外部输出发出螺丝取出的信号。
- NJR 型可通过外部输出发出螺丝取出部有无螺丝的信号。
- Provides ongoing, timely feeding of screws to match robot operations.
- The NJ type allows the screw pick-up signal to be sent through an external outlet.
- The NSR type allows for a signal to be sent through an external outlet to notify whether a screw is present at a screw pick-up point.

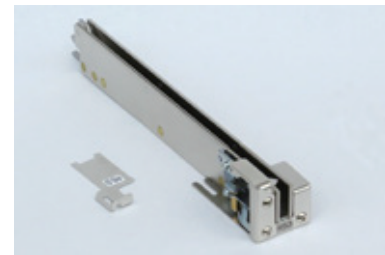

NJ 系列：更换用轨道套装 (通过板、轨道)
NJ Series: Swap rail set (passing plate, rail)

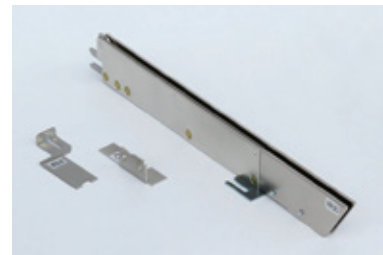

NJR 系列：更换用轨道套装 (通过板、排放器、轨道)
NJR Series: Swap rail set (passing plate, escaper, rail)



※NJ 系列：平头螺丝专用固定板
*NJ Series: Swap rail set (retainer plate for countersunk screws)

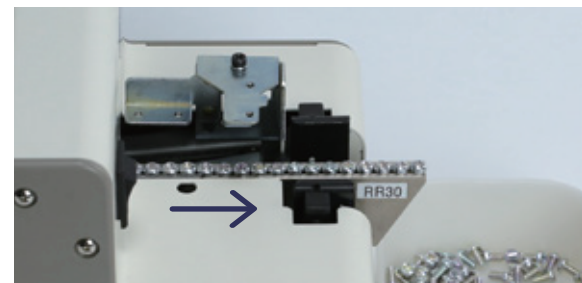

应用案例 / NJ+RR (自动机用轨道)
Sample applications / NJ + RR (rail for robotic devices)

可更换轨道 Swap rails in/out.

1 台机器可支援各种螺丝。例如，1 台 NJ-23 可适用 4 种螺丝。
根据使用螺丝的种类，可调整轨道的倾斜角度。

This single unit supports a wide range of screws. For example, the NJ-23 supports four types of screws in a single unit. Allows the angle of rail inclination to be adjusted based on the screw being used.

NJ 主体与 RR 型轨道组合使用示例

Example usage of combining NJ and RR rails

直进送料装置可为自动螺丝机连续供给螺丝。
如考虑购买其他机型的相同规格，敬请咨询。

Use as a horizontal feeder for continuous feeding to robotic devices.
If you are seeking the same functionality in a different model, please contact us.

对应手动 Manual Type



NJ-23 NJ-45



NJL-23 NJL-45

对应机器人 Robotic Type



NJR-23 NJR-45



NJRL-23 NJRL-45

带计数器 With a Counter



NJC-23 NJC-45

产品型号 Compatibility Table

适用螺丝直径 (mm)	主体型号					更换用轨道套装型号				
	NJ 系列	NJL 系列	NJR 系列	NJRL 系列	NJC 系列	NJ 系列	NJL 系列	NJR 系列	NJRL 系列	NJC 系列
2.0	NJ-2320	NJL-2320	NJR-2320	NJRL-2320	NJC-2320	R20SET	RL20SET	RR20SET	RRL20SET	R20SET
2.3	NJ-2323	NJL-2323	NJR-2323	NJRL-2323	NJC-2323	R23SET	RL23SET	RR23SET	RRL23SET	R23SET
2.6	NJ-2326	NJL-2326	NJR-2326	NJRL-2326	NJC-2326	R26SET	RL26SET	RR26SET	RRL26SET	R26SET
3.0	NJ-2330	NJL-2330	NJR-2330	NJRL-2330	NJC-2330	R30SET	RL30SET	RR30SET	RRL30SET	R30SET
3.5	NJ-4535	NJL-4535	NJR-4535	NJRL-4535	NJC-4535	R35SET	RL35SET	RR35SET	RRL35SET	R35SET
4.0	NJ-4540	NJL-4540	NJR-4540	NJRL-4540	NJC-4540	R40SET	RL40SET	RR40SET	RRL40SET	R40SET
5.0	NJ-4550	NJL-4550	NJR-4550	NJRL-4550	NJC-4550	R50SET	RL50SET	RR50SET	RRL50SET	R50SET

外观图 Model Diagrams

※ 各机型的外观图可从网站下载。
Full diagrams of each model can be downloaded from our website.

NJ 系列

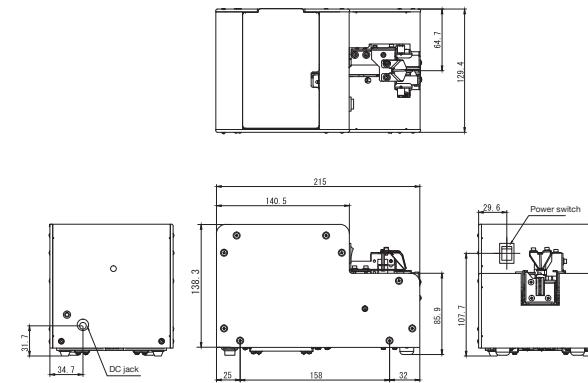

NJR 系列

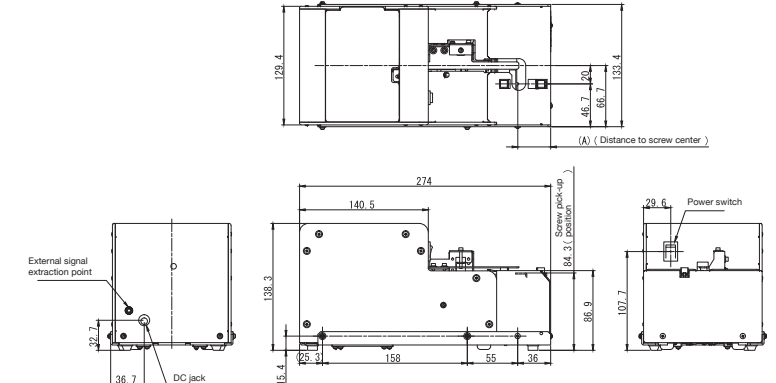

规格 Specifications

产品名称	NJ-23	NJ-45	NJL-23	NJL-45	NJR-23	NJR-45	NJRL-23	NJRL-45	NJC-23	NJC-45
外形尺寸	130(W)×215(D)×138(H)				134(W)×274(D)×139(H)				130(W)×215(D)×138(H)	
质量 (含轨道)	约 3.7kgf				约 4.4kgf				约 3.7kgf	
电源	AC100V ~ 240V DC15V 1A AC 适配器									
主体驱动马达	直流有刷电机									
超载保护与回复电路	○	○	○	○	○	○	○	○	○	○
外部输出信号线	○	○	○	○	○	○	○	○	○	○
刷毛超载防止功能	○	○	○	○	○	○	○	○	○	○
工序节拍时间	约 1.5sec									
适用螺丝直径	φ 2.0~φ 3.0	φ 3.5~φ 5.0	φ 2.0~φ 3.0	φ 3.5~φ 5.0	M2.0~M3.0	M3.5~M5.0	M2.0~M3.0	M3.5~M5.0	M2.0~M3.0	M3.5~M5.0
适用螺杆菌长度	最长至 18mm		最长至 25mm		最长至 18mm		最长至 25mm		最长至 18mm	
螺丝容量	约 150cc									
附属品及随附品	使用说明书 / AC 适配器 / 六角扳手 / 调整用螺丝刀 / 地线									

※ 如需使用其他机型的相同规格，请咨询。 *If you are looking for equivalent parts for other models, please inquire.

NSB / NSR 系列 复合型螺丝供料机

Versatile Screw Feeder

通过更换轨道，1台螺丝供料机可支援多种螺丝直径，几乎适用所有的螺丝输送作业。

Swapping rails allows you to accommodate various screw diameters with a single unit. Almost no screw is incompatible.

适用螺丝直径 M1.0~M3.0	适用螺杆长度 最长 20mm	容量 约 80cc	非铁制可 Non-ferrous materials supported
---------------------	-------------------	--------------	---

* 详细内容参考产品规格书。
For details, please refer to each product's specifications.

手动用 Manual	NSB NSBC
自动用 Robotic	NSR



⊕ 可更顺畅地输送螺丝，也大大提高了耐久性

Screws are moved smoothly, and durability has been improved dramatically

〈改进了螺丝投放口〉 Improved screw chamber

减轻对电机的负担，提高螺丝排列的效率。
Reduces strain on the motor for more efficient screw alignment.

〈轨道角度调整〉 Adjustable rail angle

可根据使用螺丝的种类调整轨道的倾斜角度。
Allows the angle of rail inclination to be adjusted based on the screw being used.

〈振幅调整〉 Amplitude adjustment

可根据使用的螺丝调整振幅。
Allows for calibrating amplitude based on the type of screw being used.

〈无横向摇摆〉 No side-to-side vibration

消除轨道横向摇摆，可更流畅地输送螺丝。
Alleviates side-to-side rail vibration to achieve smooth screw conveyance.

⊕ 其他主要特点 Other key features

- 机器体积小，不占空间。
- 配置螺丝料仓，可大容量存储。
- NSB 型可通过外部输出发出螺丝取出的信号。
- NSR 型可通过外部输出发出螺丝取出部有无螺丝的信号。

- Compact size does not take up space.
- Use a screw hopper for higher capacity.
- The NSB type allows for a screw pick-up signal to be sent through an external outlet.
- The NSR type allows for the sending out of a signal to notify whether a screw is present at a screw pick-up point through an external outlet.

■ 1台机器可适用8种螺丝直径

A single unit supports 8 different screw diameters.

- NSB 型螺丝机只需更换轨道即可适用8种螺丝直径。(标配支援 M1.0 ~ M3.0 的8种螺丝)
- NSR 型螺丝机只需更换轨道和排放器即可适用不同螺丝直径。只要从机器后部拆下轨道即可轻松去除油污等。

- The NSB type supports 8 types of screw diameters through simple rail-swapping (8 types: from M1.0 to M3.0 by default).
- The NSR type supports this through simply swapping the rail and escaper. Clean up oil and other stains easily by removing the rail from behind.



NSB 轨道 NSB rail



NSR 轨道和排放器 NSR rails and escapers

■ 一键式更换轨道

One-touch rail-swapping

轨道更换也非常简便。因螺丝直径变更而需更换轨道的情况也可以简易进行。(NSB 型)

Swapping rails based on changes in screw diameter is easy (NSB type).



对应手动 Manual Type



NSB

对应机器人 Robotic Type



NSR

带计数器 With a Counter



NSBC

产品型号 Compatibility Table

适用螺丝直径 (mm)	主体型号			更换轨道套装型号		
	NSB 系列	NSR 系列	NSBC 系列	NSB 系列	NSR 系列	NSBC 系列
1.0	NSB-10	NSR-10	NSBC-10	SR10SET	SRR10SET	SR10SET
1.2	NSB-12	NSR-12	NSBC-12	SR12SET	SRR12SET	SR12SET
1.4	NSB-14	NSR-14	NSBC-14	SR14SET	SRR14SET	SR14SET
1.7	NSB-17	NSR-17	NSBC-17	SR17SET	SRR17SET	SR17SET
2.0	NSB-20	NSR-20	NSBC-20	SR20SET	SRR20SET	SR20SET
2.3	NSB-23	NSR-23	NSBC-23	SR23SET	SRR23SET	SR23SET
2.6	NSB-26	NSR-26	NSBC-26	SR26SET	SRR26SET	SR26SET
3.0	NSB-30	NSR-30	NSBC-30	SR30SET	SRR30SET	SR30SET

外观图 Model Diagrams

* 各机型的外观图可从网站下载。
Full diagrams of each model can be downloaded from our website.

NSB 系列

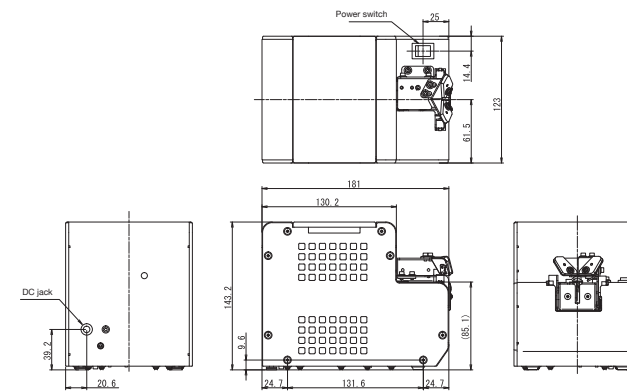

NSR 系列

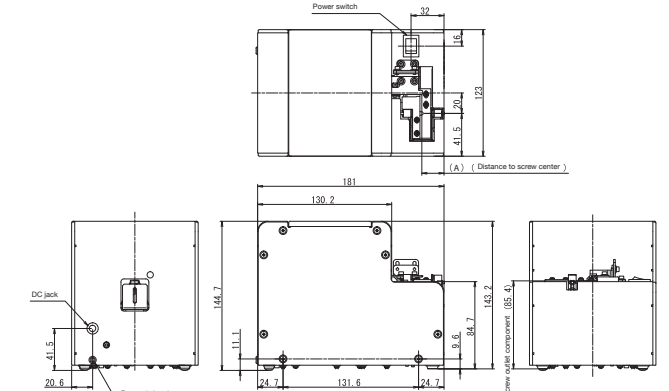

规格 Specifications

产品名称	NSB	NSR	NSBC
外形尺寸	123(W)×181(D)×145(H)		
质量 (含轨道)	约 2.9kgf	约 3.0kgf	约 2.9kgf
电源	AC100V ~ 240V DC15V 1A AC 适配器		
主体驱动马达	直流有刷电机		
超载保护与回复电路	○	○	○
外部输出信号线	○	○	○
排放器电源制动功能	-	○	-
工序节拍时间	-	约 1.5 秒	-
适用螺丝直径	M1.0 ~ M3.0		
适用螺杆长度	最长至 20mm		
螺丝容量	约 80cc		
附属品及随附品	使用说明书 / AC 适配器 / 六角扳手 / 调整用螺丝刀 / 0.35mm 仪表盘 / 地线	使用说明书 / AC 适配器 / 六角扳手 / 调整用螺丝刀 / 地线	使用说明书 / AC 适配器 / 六角扳手 / 调整用螺丝刀 / 0.35mm 仪表盘 / 地线

NSBI / NSRI 系列 复合型螺丝供料机

Versatile Screw Feeder

高精度、高速化、高耐久性

High-Precision, High-Speed, and High-Durability

适用螺丝直径 M1.0~M3.0	适用螺杆长度 最长 20mm	容量 约 80cc	非铁制可 Non-ferrous materials supported
---------------------	-------------------	--------------	---

* 详细内容参考产品规格书。
For details, please refer to each product's specifications.

手动用 Manual	NSBI
自动用 Robotic	NSRI NSRI-B (搭载无刷电机) With brushless motor



⊕ 搭载旋转式排放器 Features a rotary escaper

可将每根螺丝分开，相互间不会发生重叠，因此能顺畅地取出螺丝。
Separates screws one at a time, ensuring they do not intersect for smooth pick up.

⊕ 支援特殊螺丝 Special screws supported

可放心供给带垫片或带 SW 的螺丝。
Allows you to stably feed SW screws or those with washers.

⊕ 大大提高了电机的耐久性

Dramatic improvements in motor durability
NSRI-B：搭载无刷电机。大大提高了电机的使用寿命。（与本公司产品相比提高 3 倍以上）
NSRI-B includes a brushless motor, which has a greatly improved lifecycle (3x greater).

⊕ 灵活对应生产线变更 Flexible support for line changes

可支援不同的螺丝直径，放置在安装位置后即可，可根据工件和生产线变更的情况搬运到所需位置。
Supports screws of varying diameters. Easy installation and the portable size allow you to adapt to line or workpiece changes effortlessly.

NSRI-B 自动机搭载例

NSRI-B robotic device installation example

- 将机器放置在安装位置即可，维护或更换也非常轻松。
- NSRI/NSRI-B 在螺丝取出口有螺丝有无信号线。

- Easy installation—simply drop it into place—makes maintenance and replacement easy.
- NSRI/NSRI-B: Features a signal to notify whether a screw is at the pick-up point.



NSRI-B 自动机搭载例
NSRI-B robotic device installation example

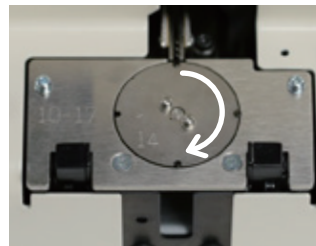

旋转式排放器
Rotating escaper

排放器部

Escaper

- 通过旋转式排放器高速供给螺丝
可准确高速地供给螺丝。
- 支援低头螺丝
标配可适用最大至 0.35 mm (特制品为 0.2 mm) 的低头螺丝。
- 可将每根螺丝分开，螺丝不会在螺丝输出口重叠在一起。

- < High-speed screw supply >
Rotating escaper accurately separates screws and supplies them at a high speed.
- < Supports low-profile screws >
Supports screws with as low a profile as 0.35mm by default (or 0.2mm by special order).
- < Clogging-free mechanism >
Separates screws one at a time, ensuring they do not clog at the pick-up outlet.

对应手动 Manual Type



NSBI

对应机器人 Robotic Type



NSRI

搭载无电刷马达 With Brushless Motor



NSRI-B

产品型号 Compatibility Table

适用螺丝直径 (mm)	主体型号			更换用轨道套装型号		
	NSBI 系列	NSRI 系列	NSRI-B 系列	NSBI 系列	NSRI 系列	NSRI-B 系列
1.0	NSBI-10	NSRI-10	NSRI-10B	BI10SET	RI10SET	RI10SET2
1.2	NSBI-12	NSRI-12	NSRI-12B	BI12SET	RI12SET	RI12SET2
1.4	NSBI-14	NSRI-14	NSRI-14B	BI14SET	RI14SET	RI14SET2
1.7	NSBI-17	NSRI-17	NSRI-17B	BI17SET	RI17SET	RI17SET2
2.0	NSBI-20	NSRI-20	NSRI-20B	BI20SET	RI20SET	RI20SET2
2.3	NSBI-23	NSRI-23	NSRI-23B	BI23SET	RI23SET	RI23SET2
2.6	NSBI-26	NSRI-26	NSRI-26B	BI26SET	RI26SET	RI26SET2
3.0	NSBI-30	NSRI-30	NSRI-30B	BI30SET	RI30SET	RI30SET2

外观图 Model Diagrams

* 各机型的外观图可从网站下载。
Full diagrams of each model can be downloaded from our website.

NSBI 系列

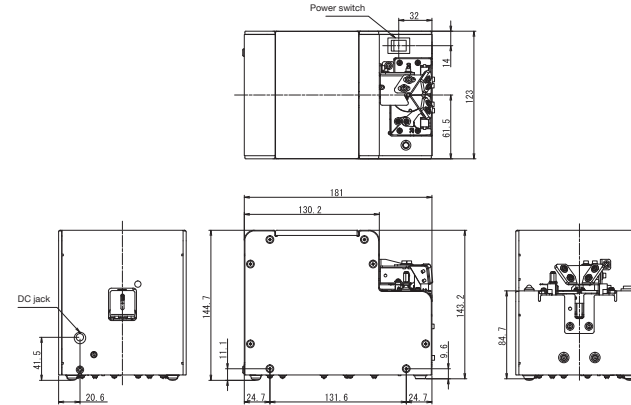

NSRI 系列

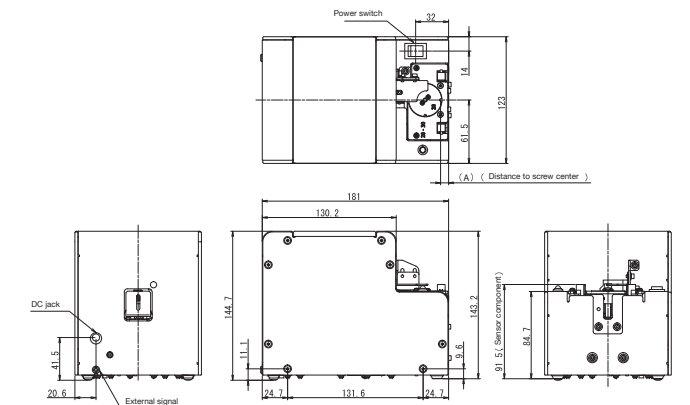

规格 Specifications

产品名称	NSBI	NSRI	NSRI-B
外形尺寸	123(W)×181(D)×145(H)		
质量 (含轨道)	约 3.0kgf		
电源	AC100V ~ 240V DC15V 1A AC 适配器		
主体驱动马达	直流有刷电机 / 步进电机		直流无刷电机 / 步进电机
超载保护与回复电路	○	○	○
外部输出信号线	○	○	○
排放器 S 型控制功能	○	○	○
排放器旋转时间差调整功能	-	-	○
工序节拍时间	约 0.9 秒		
适用螺丝直径	M1.0 ~ M3.0		
适用螺杆长度	最长至 20mm		
螺丝容量	约 80cc		
附属品及随附品	使用说明书 / AC 适配器 / 六角扳手 / 调整用螺丝刀 / 地线		

OM-26M / OM-26R系列 高速、大容量铁制螺丝供料机

High-Speed and High-Capacity Iron-Screw Feeder

大容量型号 300cc (仅适用铁制螺丝)
High-capacity model: 300cc (only supports iron screws)

适用螺丝直径 M2.0~M6.0	适用螺杆长度 最长 25mm	容量 约 300cc	铁制螺丝专用 For iron screws
---------------------	-------------------	---------------	---------------------------

* 详细内容参考产品规格书。
For details, please refer to each product's specifications.

手动用 Manual	OM-26M
自动用 Robotic	OM-26R OM-26RB (搭载无刷电机) With brushless motor



⊕ 搭载旋转式排放器 Features a rotary escaper

可将每根螺丝分开，相互间不会发生重叠，因此能顺畅地取出螺丝。
Separates screws one at a time, ensuring they do not intersect for smooth pick up.

⊕ 支援各螺丝刀厂家的标准钻头。

Supports standard bits from various screwdriver manufacturers

- 钻头式螺丝刀 Bit screwdrivers.
- 气吸式螺丝刀 Suction screwdrivers.

⊕ 大容量 300cc Large capacity: 300 cc

可存放约 780 个 M3.0x12mm 底座螺丝。
Supports a stock of approx. 780 M3.0 x 12mm washer-faced screws.

⊕ 支援特殊螺丝 Special screws supported

可放心供给带垫片或带 SW 的螺丝。
Allows you to stably feed SW screws or those with washers.

⊕ 大大提高了电机的耐久性

Dramatic improvements in motor durability
OM-26RB：搭载无刷电机大大提高了电机的使用寿命。
(与公司产品相比提高 3 倍以上)
OM-26RB is equipped with a brushless motor, which has a greatly improved lifecycle (3x greater).

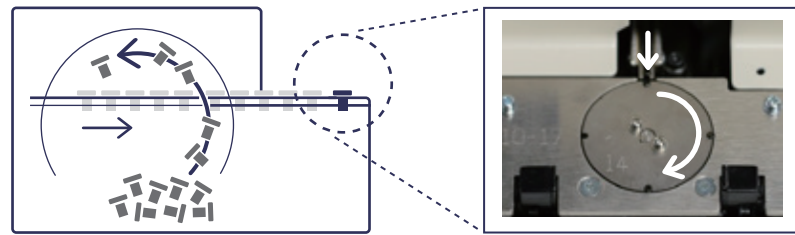

通过磁力可稳定输出螺丝到轨道上
Magnetically conveys screws along rails for a stable feeding

旋转式排放器
Rotating escaper

可大量存放螺丝：存放量约 NSB 的 4 倍

High-capacity screw stock (4x that of the NSB type)
通过磁力可稳定输出螺丝至轨道。其结构不会造成螺丝堵塞。此外，旋转式排放器将每根螺丝分开，可防止螺丝取出时发生错误。

Magnetically conveys screws along rails for a stable feed. Its design prevents screws from getting stuck. The rotating escaper also isolates screws one at a time to prevent picking-up errors.

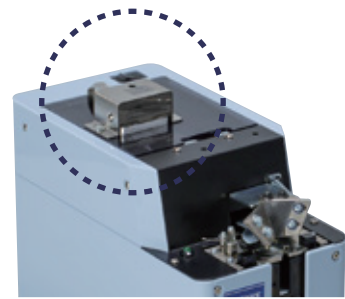

选装产品：余量传感器 Optional: quantity sensor

OM-26R/M 用螺丝余量传感器 (TKA09452)
“自动螺丝供料机 OM-26R/M 系列”专用的螺丝余量传感器 (TKA09452)。
与 OM-26R/M 组合使用，可检测出螺丝余量变少，向外部发出信号。
关于其他产品的余量传感器，敬请咨询。

OM-26R/M screw quantity sensor (TKA09452)
This is a screw quantity sensor (TKA09452) intended for use with the OM-26R/M Series Automatic Screw Feeder. Combine with the OM-26R/M to detect when the screw stock is low and send a signal. Please contact us regarding quantity sensors for other products.

对应手动 Manual Type



OM-26M

对应机器人 Robotic Type



OM-26R

搭载无电刷马达 With Brushless Motor



OM-26RB

产品型号 Compatibility Table

适用螺丝直径 (mm)	主体型号			更换用轨道套型号		
	OM-26M 系列	OM-26R 系列	OM-26RB 系列	OM-26M 系列	OM-26R 系列	OM-26RB 系列
2.0	OM-26M20	OM-26R20	OM-26RB20	OMM20SET	OMR20SET	OMR20SET2
2.3	OM-26M23	OM-26R23	OM-26RB23	OMM23SET	OMR23SET	OMR23SET2
2.6	OM-26M26	OM-26R26	OM-26RB26	OMM26SET	OMR26SET	OMR26SET2
3.0	OM-26M30	OM-26R30	OM-26RB30	OMM30SET	OMR30SET	OMR30SET2
3.5	OM-26M35	OM-26R35	OM-26RB35	OMM35SET	OMR35SET	OMR35SET2
4.0	OM-26M40	OM-26R40	OM-26RB40	OMM40SET	OMR40SET	OMR40SET2
5.0	OM-26M50	OM-26R50	OM-26RB50	OMM50SET	OMR50SET	OMR50SET2
6.0	OM-26M60	OM-26R60	OM-26RB60	OMM60SET	OMR60SET	OMR60SET2

外观图 Model Diagrams

* 各机型的外观图可从网站下载。
Full diagrams of each model can be downloaded from our website.

OM-26M 系列

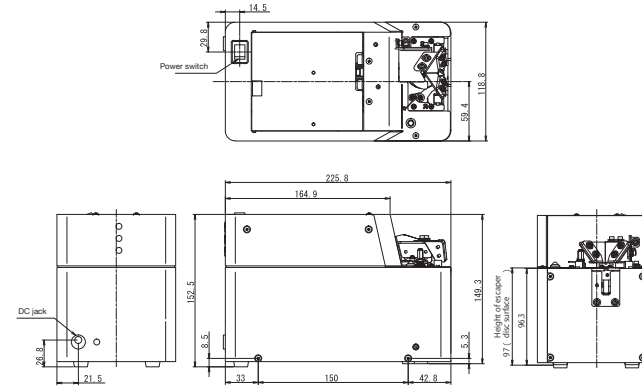

OM-26R 系列

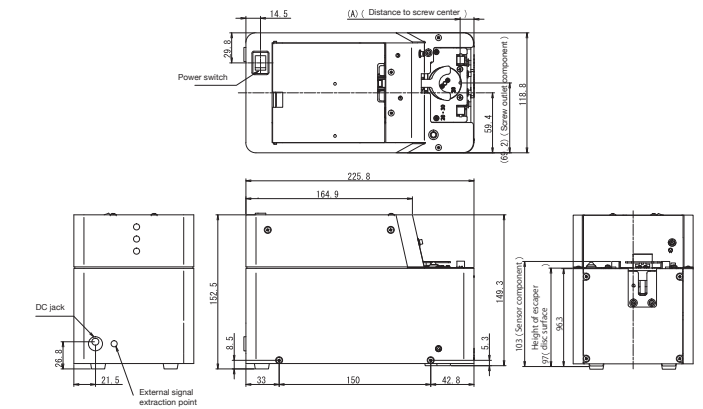

规格 Specifications

产品名称	OM-26M	OM-26R	OM-26RB
外形尺寸	119(W)×226(D)×152(H)		
质量 (含轨道)	约 3.1kgf		
电源	AC100V ~ 240V DC15V 1A AC 适配器		
主体驱动马达	直流有刷电机 / 步进电机		直流无刷电机 / 步进电机
超载保护与回复电路	○	○	○
外部输出信号线	○	○	○
外部输出信号线 (余量传感器)	选装		
排放器 S 型控制功能	○	○	○
排放器旋转 时间差调整功能	-	-	○
工序节拍时间	约 0.8 秒		
适用螺丝材质	只限铁制		
适用螺丝直径	M2.0 ~ M6.0		
适用螺杆长度	最长至 25mm		
螺丝容量	约 300cc		
附属品及随附品	使用说明书 / AC 适配器 / 六角扳手 / 调整用螺丝刀 / 地线		

MSF 系列 微型螺丝供料机

Micro-Screw Feeder

可适用最小至 S0.5 的螺丝
Supports screws as small as S0.5

适用螺丝直径 S0.5~S1.0	适用螺杆长度 最长 5mm	容量 约 15cc	非铁制可 Non-ferrous materials supported
---------------------	------------------	--------------	---

※ 详细内容参考产品规格书。
For details, please refer to each product's specifications.

自动用 MSF
Robotic

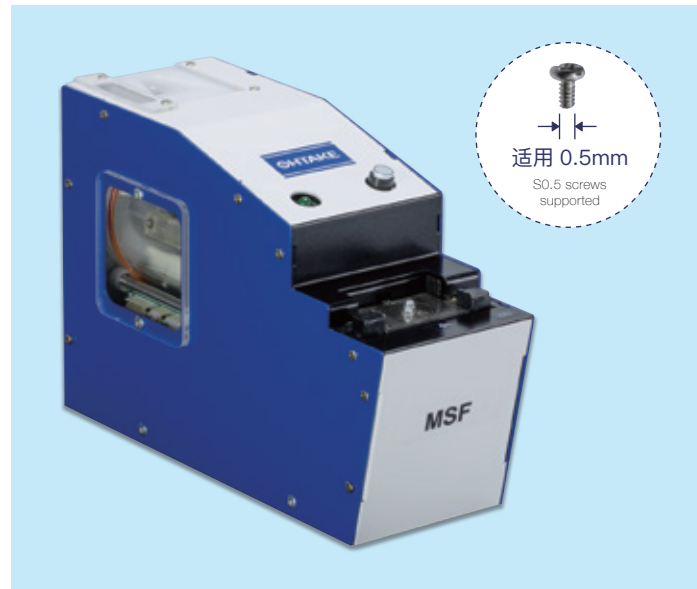

可准确分选微型螺丝

Accurately and reliably isolates tiny screws
采用旋转式排放器可分选微型螺丝并将其逐根分离。
Rotating escaper isolates even tiny screws one by one.

节省空间的薄型机身

Slim, space-saving design
产品宽度为 70mm，不占空间。
Compact, 70mm-wide design saves space.

设置简便

Simple installation
放置在安装位置即可，非常简便。
No need for complex and time-consuming installation—just set it in place

自动机搭载例

Example of installation for a robotic device

- 将机器放置在安装位置即可，维护或更换也非常轻松。
- 螺丝取出部有螺丝有无信号线。
- 通过旋转式排放器准确地输出螺丝。

- Easy installation makes maintenance and replacement easy.
- Features a signal to notify whether a screw is at the pick-up point.
- Rotating escaper ensures accurate screw feed.



规格 Specifications

产品名称	MSF
外形尺寸	71(W)×194(D)×132(H)
质量 (含轨道)	约 2kgf
电源	AC100V ~ 240V DC15V 1A AC 适配器
主体驱动马达	直流有刷电机 / 步进电机
外部输出终端	○
适用螺丝直径	S0.5 ~ S1.0
适用螺杆长度	1 ~ 5mm
螺丝容量	约 15cc
附属品及随附品	使用说明书 / AC 适配器 / 六角扳手 / 调整用螺丝刀 / 地线

产品型号 Compatibility Table

适用螺丝直径 (mm)	主体型号 MSF 系列
0.5	MSF-05
0.6	MSF-06
0.7	MSF-07
0.8	MSF-08
1.0	MSF-10

外观图 Model Diagrams

※ 各机型的外观图可从网站下载。
Full diagrams of each model can be downloaded from our website.

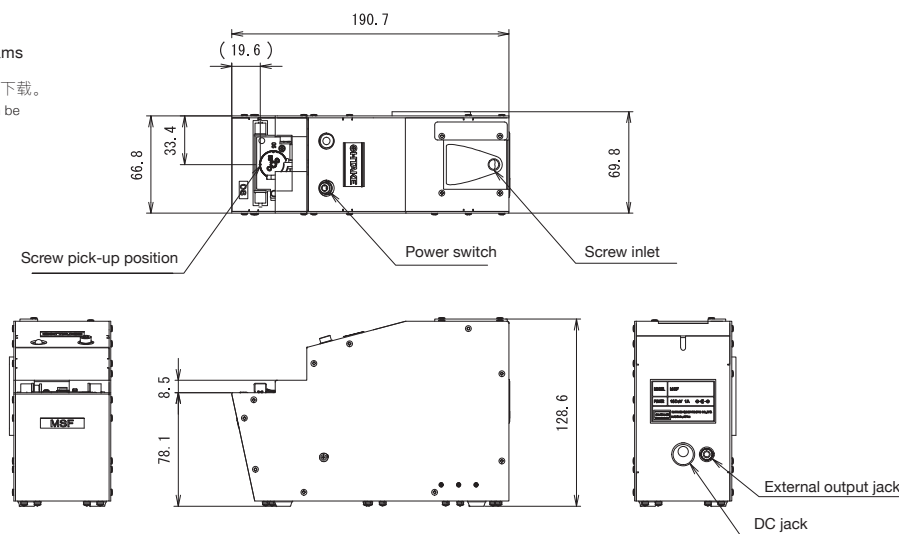

※ 订购前请务必咨询。
*Please inquire prior to placing an order.

SS 系列 薄型螺丝供料机

Slim Screw Feeder

宽度 55mm，是最适合单元化生产的超薄型系列
Super-thin 55mm width is ideal for cell work

适用螺丝直径 M1.0~M3.0	适用螺杆长度 最长 16mm	容量 约 40cc	非铁制可 Non-ferrous materials supported
---------------------	-------------------	--------------	---

※ 详细内容参考产品规格书。
For details, please refer to each product's specifications.

手动用 SS-12 SS-23
Manual



规格 Specifications

产品名称	SS-12	SS-23
外形尺寸	55(W)×205(D)×143(H)	
质量 (含轨道)	约 2.4kgf	
电源	AC100V ~ 240V DC15V 1A AC 适配器	
主体驱动马达	直流有刷电机	
超载保护与回复电路	○	○
适用螺丝直径	M1.0 ~ M2.0	M2.3 ~ M3.0
适用螺杆长度	最长至 16mm	
螺丝容量	约 40cc	
附属品及随附品	使用说明书 / AC 适配器 / 六角扳手 / 调整用螺丝刀 / 地线	

产品型号 Compatibility Table

适用螺丝直径 (mm)	SS 系列	
	主体型号	更换用轨道套装型号
1.0	SS-1210	WR10
1.2	SS-1212	WR12
1.4	SS-1214	WR14
1.7	SS-1217	WR17
2.0	SS-1220	WR20
2.3	SS-2323	WR23
2.6	SS-2326	WR26
3.0	SS-2330	WR30

外观图 Model Diagrams

※ 各机型的外观图可从网站下载。
Full diagrams of each model can be downloaded from our website.

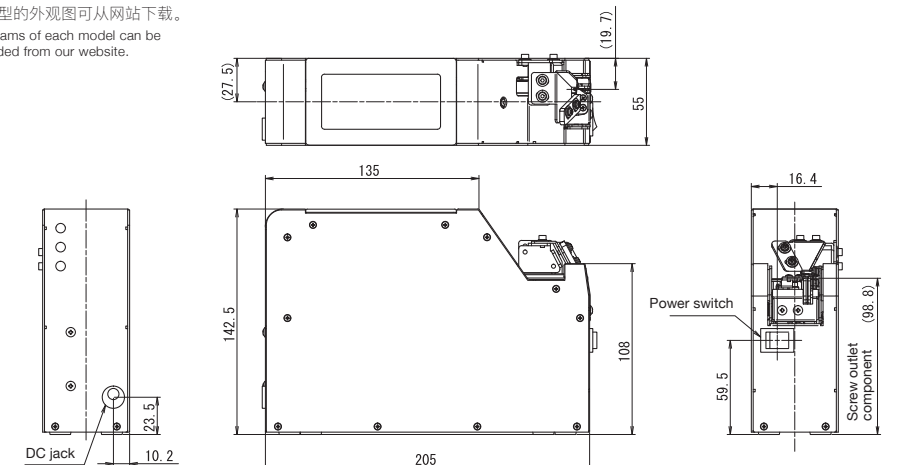

设计轻巧，可并排放置使用

Slim design allows them to be installed next to each other
宽度仅为 NJ/NS 系列一半以下，放置 1 台 NSB 的空间可放置两台 SS 系列产品。
In less than half the width of the NJ/NS series, for the space of a single NSB series model, for example, you can fit two units.

支援低头螺丝

Supports low-profile screws
通过调整传感器，可适用头部最大至 0.25mm 的螺丝 (初期设定为 0.5mm)
Adjust sensor to support screw heads as low as (factory setting: 0.5mm)

可调整螺丝输送速度

Adjustable screw conveyor speed
通过调整振幅和频率，可调整至最佳的螺丝输送速度。
Calibrate amplitude and frequency to achieve the ideal feed speed.

单元化生产和多个螺丝锁付作业

Space-saving for cell work and multiple screw-tightening work.



SSI-M / SSI-R 系列 薄型螺丝供料机

Slim Screw Feeder

可支援多样化的装配现场，不受安装场地限制
Compact size supports a wide range of assembly workflows and fits anywhere

适用螺丝直径 M1.0~M3.0	适用螺杆长度 最长 16mm	容量 约 40cc	非铁制可 Non-ferrous materials supported
---------------------	-------------------	--------------	---

* 详细内容参考产品规格书。
For details, please refer to each product's specifications.

手动用 SSI-12M SSI-23M
自动用 SSI-12R SSI-23R



← 65mm → ← 65mm →

⊕ 节省空间的薄型机身 Slim, space-saving design

产品宽度为 65mm，不占空间。
Compact, 65mm-wide design saves space.

⊕ 螺丝不会堵塞，轨道运行稳定

Stable rail movement without clogging
使用水平输送方式可防止螺丝之间的重叠和堵塞，实现了稳定供给。
Horizontal rail system prevents screws from clogging or overlapping, achieving stable feeding.

⊕ 通用型计数器输出标配

Integrated output designed for use with general counters
从输出接口获得螺丝输出信号，可与通用型计数器等连接。
Send pick-up signal from output jack to connect a general-purpose counter.

对应手动 Manual Type



SSI-12M SSI-23M

对应机器人 Robotic Type



SSI-12R SSI-23R

产品型号 Compatibility Table

适用螺丝直径 (mm)	主体型号		更换用轨道套装型号	
	SSI-M 系列	SSI-R 系列	SSI-M 系列	SSI-R 系列
1.0	SSI-12M10	SSI-12R10	SIM10SET	SIR10SET
1.2	SSI-12M12	SSI-12R12	SIM12SET	SIR12SET
1.4	SSI-12M14	SSI-12R14	SIM14SET	SIR14SET
1.7	SSI-12M17	SSI-12R17	SIM17SET	SIR17SET
2.0	SSI-12M20	SSI-12R20	SIM20SET	SIR20SET
2.3	SSI-23M23	SSI-23R23	SIM23SET	SIR23SET
2.6	SSI-23M26	SSI-23R26	SIM26SET	SIR26SET
3.0	SSI-23M30	SSI-23R30	SIM30SET	SIR30SET

外观图 Model Diagrams

* 各机型的外观图可从网站下载。
Full diagrams of each model can be downloaded from our website.

SSI-M 系列

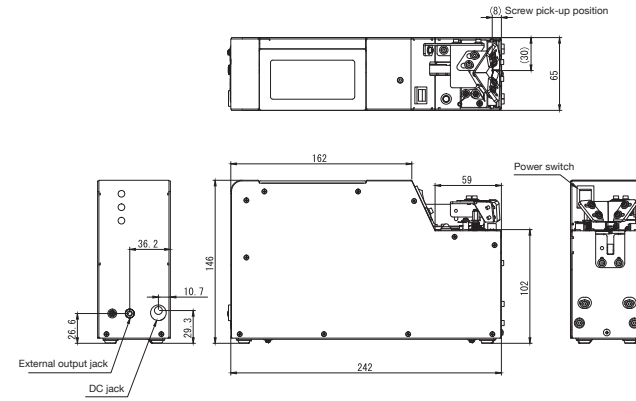

SSI-R 系列

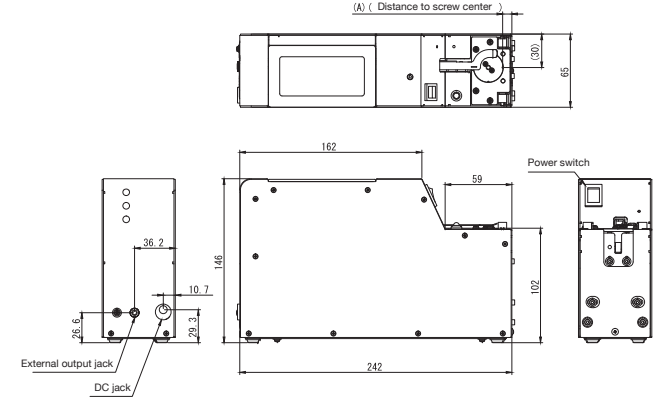

规格 Specifications

产品名称	SSI-12M	SSI-23M	SSI-12R	SSI-23R
外形尺寸	65(W)×242(D)×146(H)			
质量 (含轨道)	约 3.3kgf		约 3.2kgf	
电源	AC100V ~ 240V DC15V 1A AC 适配器			
主体驱动马达	直流有刷电机 / 步进电机			
超载保护与回复电路	○	○	○	○
外部输出终端	○	○	○	○
排放器 S 型控制功能	○	○	○	○
工序节拍时间	约 0.9 秒			
适用螺丝直径	M1.0 ~ M2.0	M2.3 ~ M3.0	M1.0 ~ M2.0	M2.3 ~ M3.0
适用螺杆长度	最长至 16mm			
螺丝容量	约 40cc			
附属品及随附品	使用说明书 / AC 适配器 / 六角扳手 / 调整用螺丝刀 / 地线			

背部说明 Rear part description



SSI 背部
SSI rear part

← 频率
← 振动
← 计时器

根据频率和振动数调整螺丝的输送速度
Calibrate screw feeding speed by frequency and vibration

排放器部 Escaper

- 通过旋转式排放器高速供给螺丝
可准确高速地供给螺丝。
- 支援低头螺丝
标配可适用最大至 0.35 mm (特制品为 0.2 mm) 的低头螺丝。
- 可将每根螺丝分开，螺丝不会在螺丝输出口重叠在一起。

- < High-speed screw supply >
Rotating escaper accurately separates screws and supplies them at a high speed.
- < Supports low-profile screws >
Supports screws with as low a profile as 0.35mm by default (or 0.2mm by special order).
- < Clogging-free mechanism >
Separates screws one at a time, ensuring they do not clog at the pick-up outlet.

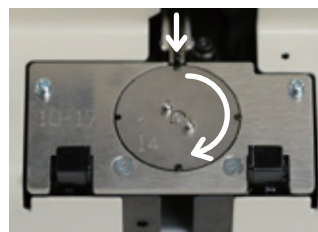

旋转式排放器
Rotating escaper

FM 系列

定量计数器 / 外部设定型 螺丝供料机

Fixed Quantity Count / External Configuration Type Screw Feeder

准确提供所设定的螺丝数量

Accurately feeds a set number of screws

适用螺丝直径 M3.0~M6.0	适用螺杆长度 最长 25mm	容量 约 150cc	非铁制可 Non-ferrous materials supported
---------------------	-------------------	---------------	---

* 详细内容参考产品规格书。
For details, please refer to each product's specifications.

定量取出 Fixed-quantity pick up FM-36 FME-36 (外部设定型) External configuration



按照输入在计数器里的螺丝数量准确供料

Accurately feeds the number of screws input to counter
可设定 1~99 根的使用数量。并准确计算和排放出所设定的数量。
Set between 1 and 99. Accurately counts and expels the number you set.

螺丝不会堵塞，轨道运行稳定

Stable rail movement without clogging
使用水平输出方式可防止螺丝之间的重叠和堵塞，实现了稳定供给。
Horizontal rail system prevents screws from clogging or overlapping, achieving stable feeding.

灵活对应生产线变更 Flexible support for line changes

可支援不同的螺丝直径，放置在安装位置后即可，可根据工件和生产线变更的情况搬运到所需位置。
Supports screws of varying diameters. Easy installation and the portable size allow you to adapt to line or workpiece changes effortlessly.

与螺丝料仓组合使用可使机器长时间运行

Long-running operation when combined with screw hopper
FM 主体可存放 150cc，配置螺丝料仓后可增加存放 400 ~ 1600cc 的螺丝。
FM unit has capacity of 150cc—add screw hopper for additional 400~1600cc stock.

计数器 Counter

- 设定螺丝数量 0 ~ 99 根
 - 显示次数 0 ~ 9999 次
 - 带外部输出信号
 - 带停电时存储器保护功能
- Set number of screws between 0-99
- Set number of times between 0-9999
- External pick-up signal
- Power outage memory-protection feature



支持螺母定量输出

Fixed-quantity pick up with nut support
通过特别定制，也可商讨对应螺母定量输出的型号。如有任何需求欢迎咨询。

By special order, we can consider the fixed-quantity nut pick up model. Please do not hesitate to contact us.



可通过通信更改输出螺丝的数量 (FME-36)

Connect to unit for variable pick-up quantity (FME-36)

可通过各公司的 PLC 更改定量螺丝供料机的设定。*PLC 用界面 (NEX-PLC) 为 FME-36 专用型号。

Change the setting using a PLC of a variety of manufacturers. *The PLC interface (NEX-PLC) is exclusively for use with the FME-36.

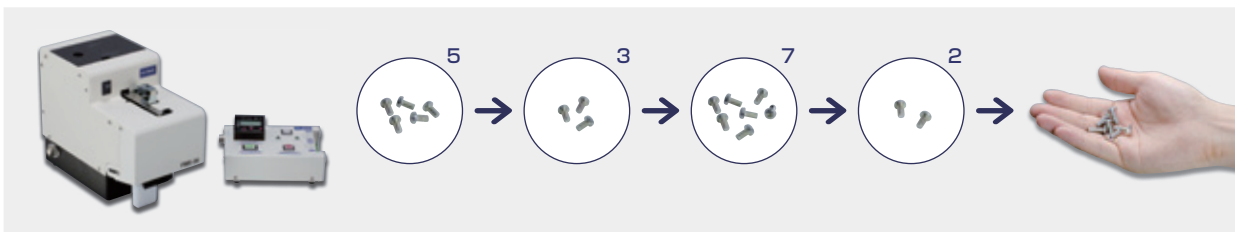

定量取出 Fixed quantity pick up



FM-36

支持定量取出 PLC Fixed-quantity pick up with PLC support

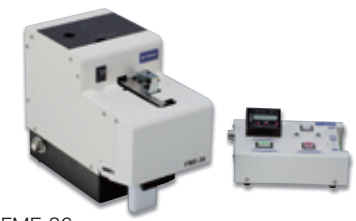

FME-36

产品型号 Compatibility Table

适用螺丝直径 (mm)	主体型号		更换用轨道套装型号
	FM 系列	FME 系列	FM/FME 系列通用
3.0	FM-3630	FME-3630	FR30SET
3.5	FM-3635	FME-3635	FR35SET
4.0	FM-3640	FME-3640	FR40SET
5.0	FM-3650	FME-3650	FR50SET
6.0	FM-3660	FME-3660	FR60SET

外观图 Model Diagrams

* 各机型的外观图可从网站下载。
Full diagrams of each model can be downloaded from our website.

FM-36 系列

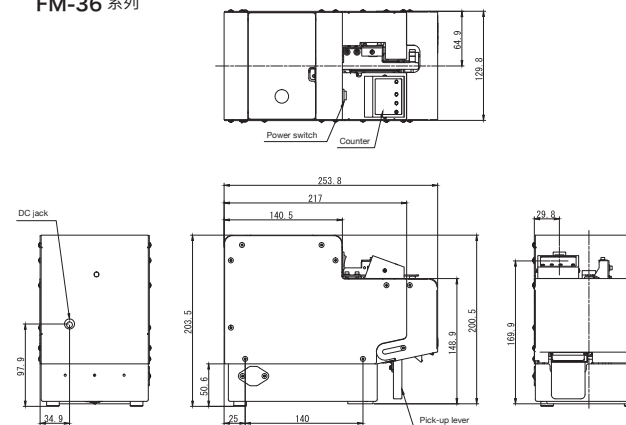

FME-36 系列

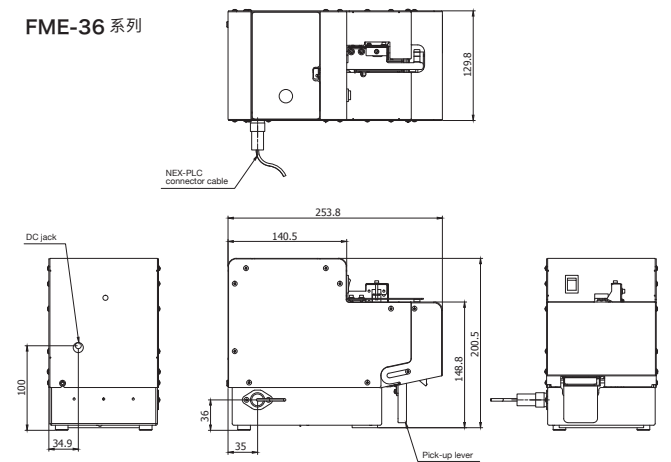

规格 Specifications

产品名称	FM-36	FME-36
主体外形尺寸	130(W)×254(D)×201(H)	
主体质量 (含轨道)	约 6.0kgf	
主体电源	AC100V ~ 240V DC15V 1A AC 适配器	
主体驱动马达	直流有刷电机	
超载保护与回复电路	○	
外部输出信号线	○	
刷毛超载防止功能	○	
设定根数	最多 99 根	最多 127 根
适用螺丝直径	M3.0 ~ M6.0	
适用螺杆长度	最长至 25mm	
螺丝容量	约 150cc	
附属品及随附品	使用说明书 / AC 适配器 / 六角扳手 / 调整用螺丝刀 / 地线	
扩充储存盒外形尺寸	-	155(W)×113(D)×44(H)
扩充储存盒电源	-	AC100V ~ 240V DC24V 1.9A AC 适配器

* 根据螺丝尺寸，有可能无法一次性取出 99 根螺丝。
*Note that some screw sizes may not support pick up of 99 units.

LS/LV/LF 系列 大型长螺丝供料机

Large, Longneck Screw Feeder

适用最大螺丝和螺栓直径至 8.0、螺杆 50 mm。
可应用于汽车组装、建筑、翻新等

Supports screws and bolts with a diameter of up to M8.0 and an under-head length of 50mm.
Ideal for feeding screws and bolts for automotive assembly, construction, and renovation.



大容量 Large capacity

可大量存放 1000~1300cc。
High-capacity stock: between 1000~1300cc

可满足各种需求

Capable of supporting a range of needs

根据工件或用途，有 6 种类型可供选择。
(请参考取出类型示例)

Comes with six patterns that you can select based on the type of workpiece and the intended use. (Please refer to the suggested pick-up patterns described below)

适用铆钉 (LF50) Rivets supported

可以定量排列铆钉。
无需手动改变铆钉的排列方向，可大幅提高作业效率。
Fixed-quantity alignment of rivets is supported.
Work efficiency is greatly improved because there is no need to reorient rivets by hand.

适用螺丝直径 M3.0~M8.0	适用螺杆长度 最长 25/50mm	容量 约 1000cc/ 1300cc	铁制螺丝专用 For iron screws
---------------------	----------------------	---------------------------	---------------------------

* 详细内容参考产品规格书。
For details, please refer to each product's specifications.

手动用 Manual	LS25-HM LS-50HM
自动用 Robotic	LS25-HR LS-50HR
定量取出 Fixed quantity take out	LV25 LV50 LF50

适用最大直径 3.0 mm ~ 8.0 mm 的螺丝和螺栓

Supports screws and bolts of 3.0mm~8.0mm diameters

以水平输送稳定供给大型工件。

最多可设定 999 个，无需要进行费时的数量确认。

Achieves a stable, horizontal feed even for large workpieces.

Configure up to 999 pieces. No need to check the screw quantity each time.



取出类型示例 Suggested pick-up patterns

手动 Manual

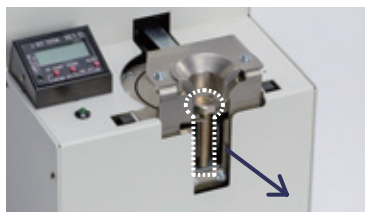

LS25-HM / LS50-HM

机器 Robotic

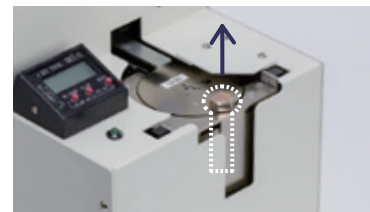

LS25-HR / LS50-HR

手柄式取出 Lever



LV25-S / LV50-S

排出固定数量 Fixed-quantity



LV25-H / LV50-H

将固定数量投入箱子 Feed fixed quantity to box



LV25-B / LV50-B

将固定数量投入轨道 Feed fixed quantity to rail



LF50

对应手动 Manual Type

对应机器人 Robotic Type

带计数器 With a Counter



LS25-HM LS-50HM LS25-HR LS-50HR LV25-S LV50-S LV25-B LV50-B LV25-H LV50-H LF50

产品型号 Compatibility Table

适用螺丝直径 (mm)	主体型号					
	LS-HM 系列		LS-HR 系列		LV 系列	
	螺杆最长至 25mm	螺杆最长至 50mm	螺杆最长至 25mm	螺杆最长至 50mm	螺杆最长至 25mm	螺杆最长至 50mm
3.0	LS25-HM30	LS50-HM30	LS25-HR30	LS50-HR30	LV25-30	LV50-30
3.5	LS25-HM35	LS50-HM35	LS25-HR35	LS50-HR35	LV25-35	LV50-35
4.0	LS25-HM40	LS50-HM40	LS25-HR40	LS50-HR40	LV25-40	LV50-40
5.0	LS25-HM50	LS50-HM50	LS25-HR50	LS50-HR50	LV25-50	LV50-50
6.0	LS25-HM60	LS50-HM60	LS25-HR60	LS50-HR60	LV25-60	LV50-60
8.0	LS25-HM80	LS50-HM80	LS25-HR80	LS50-HR80	LV25-80	LV50-80

适用心轴直径 (mm)	主体型号 LF 系列 螺杆最长至 50mm
2.0	LF50-20
2.3	LF50-23
2.6	LF50-26

外观图

Model Diagrams

* 各机型的外观图可从网站下载。

Full diagrams of each model can be downloaded from our website.

LS-HM 系列

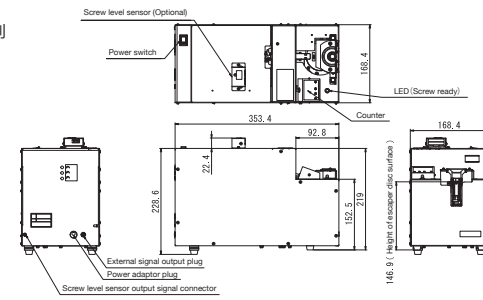

LS-HR 系列

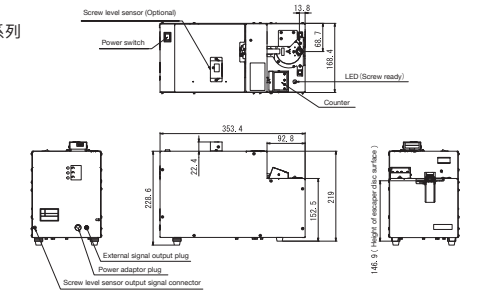

LV 系列

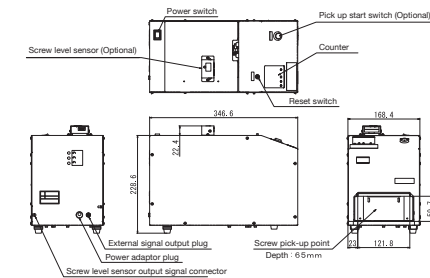

LF 系列

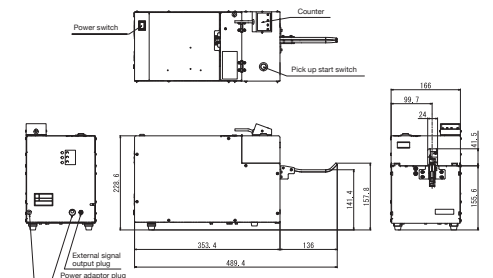

规格 Specifications

产品名称	LS25-HM	LS50-HM	LS25-HR	LS50-HR	LV-25	LV-50	LF-50
外形尺寸	169(W)×354(D)×229(H)				169(W)×347(D)×229(H)		169(W)×354(D)×229(H) 前方轨道突出部: 136mm
质量 (含轨道)	约 15kgf						
电源	AC100V ~ 240V DC15V 1A AC 适配器						
主体驱动马达	直流无刷电机 / 直流有刷电机						
超载保护与回复电路	○	○	○	○	○	○	○
外部输出终端	○	○	○	○	○	○	○
安全功能	储存库盖打开时停止动作						
适用螺丝直径	M3.0 ~ M8.0		M3.0 ~ M8.0		M3.0 ~ M8.0		φ 2 ~ φ 2.6 (有实绩)
适用螺杆长度	最长至 25mm	最长至 50mm	最长至 25mm	最长至 50mm	最长至 25mm	最长至 50mm	最长至 50mm
螺丝容量	约 1300cc	约 1000cc	约 1300cc	约 1000cc	约 1300cc	约 1000cc	约 1000cc
附属品及随附品	使用说明书 / AC 适配器 / 六角扳手 / 调整用螺丝刀 / 地线						

* 订购前请务必咨询。需要确认使用的工件与钻头。

*Please inquire before placing an order. You are required to check the work bit you are using.

BS 系列

气力压送式螺丝供料机

Pneumatic Screw Feeder

通过气压瞬间压送螺丝

Pneumatically feeds screws to their destination in an instant.

适用螺丝直径 M2.0~M6.0	适用螺杆长度 最长 12/14/25mm	容量 约 80cc~1300cc	铁制螺丝专用 For iron screws 非铁制可 Non-ferrous materials supported
----------------------------	--------------------------------	----------------------------	--

* 详细内容参考产品规格书。
For details, please refer to each product's specifications.

手动用 Manual	BS-D
自动用 Robotic	BS(S) BS(L) BS-P BS-R
定量取出 Fixed quantity take out	BS-C * BS-P 任何材质均可 / BS-P 以外为铁制螺丝专用 / Other models only for iron screws



通过空气的力量将螺丝压送至其他位置

Uses air pressure to convey screws to distant locations

通过气压将螺丝压送到手边。大大提高了作业效率。

* 附带的标准软管为 2.5m。必须有空气配管。

Brings screws right to you using air pressure, dramatically improving work efficiency.
*The default hose is 2.5 meters long and requires air tubing to be installed.

节省空间，大容量

Space-saving, high-capacity model

螺丝供给部和输出部的分离设计，不占用作业场所的空间。

Separating the screw feed from pick-up points allows for a space-saving design.

根据用途提供 4 种类型

Space-saving and high-capacity in one model

BS (手动和自动机用)：根据各外部信号压送螺丝。

BS-R (自动机用)：通过滑动单元将螺丝压送给螺丝刀，大幅缩短工序节拍时间。

BS-C (定量一次性取出)：取出计数器设定数量的螺丝，按一下箱体上的手柄即可取出螺丝。

BS-D (定量单个取出)：逐根取出设定数量的螺丝和螺栓。

BS (manual and robotic): Pneumatically feeds screws in response to an external signal.
BS-R (robotic pick up): Sliding unit conveys screws to screwdriver pneumatically, greatly cutting down on yield time.

BS-C (fixed-quantity bulk pick up): Pick up the set quantity with the counter and it allows for pick up by simply pulling the lever.

BS-D (fixed-quantity single pick up): Pick up the set number of screws and bolts one at a time next to your hand.

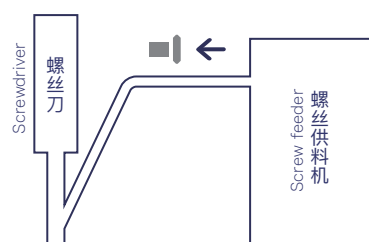

[BS]

- 按照外部信号的要求压送螺丝。
- 将螺丝供应到螺丝刀的 Y 管等。
- 可用于自动螺丝锁付机器人和手动螺丝锁付螺丝刀。

- Screws are pneumatically fed by request through an external signal.
- Screws are fed to the screwdriver's Y pipe with the screw side at the front.
- It is compatible with the robotic and manual screwdrivers.

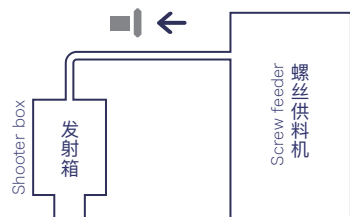

[BS-C]

- 可一次性取出定量螺丝。
- 将螺丝供给机安装在作业区域外，可节省作业区域的空间。
- 定量功能有助防止忘记螺丝锁付作业。

- Fixed quantities of screws are picked up in bulk.
- The screw feeder can be placed outside the workspace, saving more space for work.
- Fixed quantity pick up can prevent screw-tightening being forgotten.

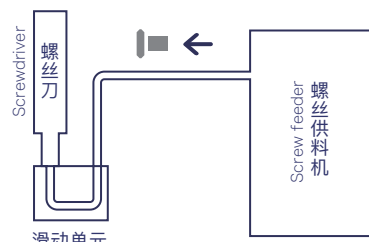

[BS-R]

- 按照外部信号的要求压送螺丝。
- 在螺丝刀旁边设置滑动单元的螺丝供给部，能缩短螺丝供给至螺丝刀的时间。
- 螺丝在螺丝刀的下方供给。
- 可用于自动螺丝锁付机器人。

- Screws are pneumatically fed by request through an external signal.
- Placing the screw-feeding part of the slide unit near the screwdriver can shorten the time it takes to feed screws to the screwdriver.
- Screws are fed with the head at the front.
- It is compatible with screw-tightening robots.

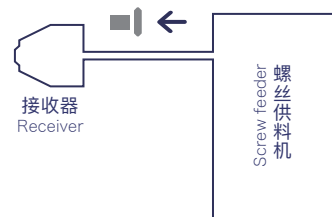

[BS-D]

- 逐根取出定量的螺丝。
- 将螺丝供给机安装在作业区域外，可节省作业区域的空间。
- 螺丝供给至螺丝锁付作业者的手边。
- 定量功能有助防止忘记螺丝锁付作业。

- Fixed quantities of screws are picked up one at a time.
- The screw feeder can be placed outside the workspace, saving space for work.
- It feeds the screw next to the hand doing the screw-tightening work.
- Fixed quantity pick up can prevent screw-tightening being forgotten.

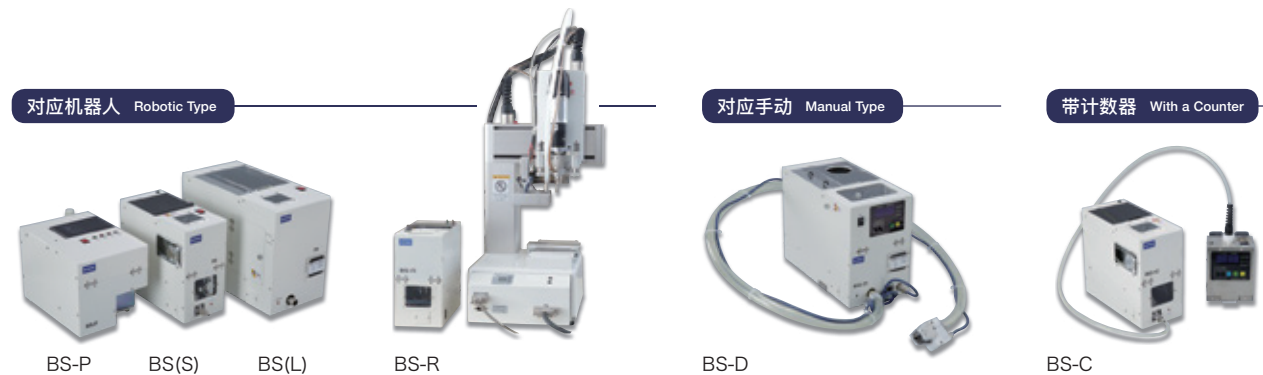

产品型号 Compatibility Table

适用螺丝直径 (mm)	主体型号					
	BS 系列		BS-R 系列	BS-D 系列	BS-C 系列	
	螺丝提供口容量 最大约 280cc	螺丝提供口容量 最大约 1300cc	-	-	螺丝提供口容量 最大约 280cc	螺丝提供口容量 最大约 1300cc
2.0	BS-S20	BS-L20	BS-R20	-	BS-CS20	BS-CL20
2.3	BS-S23	BS-L23	BS-R23	-	BS-CS23	BS-CL23
2.6	BS-S26	BS-L26	BS-R26	-	BS-CS26	BS-CL26
3.0	BS-S30	BS-L30	BS-R30	BS-D30	BS-CS30	BS-CL30
3.5	BS-S35	BS-L35	BS-R35	BS-D35	BS-CS35	BS-CL35
4.0	BS-S40	BS-L40	BS-R40	BS-D40	BS-CS40	BS-CL40
5.0	BS-S50	BS-L50	BS-R50	BS-D50	BS-CS50	BS-CL50
6.0	BS-S60	BS-L60	-	BS-D60	BS-CS60	BS-CL60

外观图

* 各机型的外观图可从网站下载。

Full diagrams of each model can be downloaded from our website.

Model Diagrams

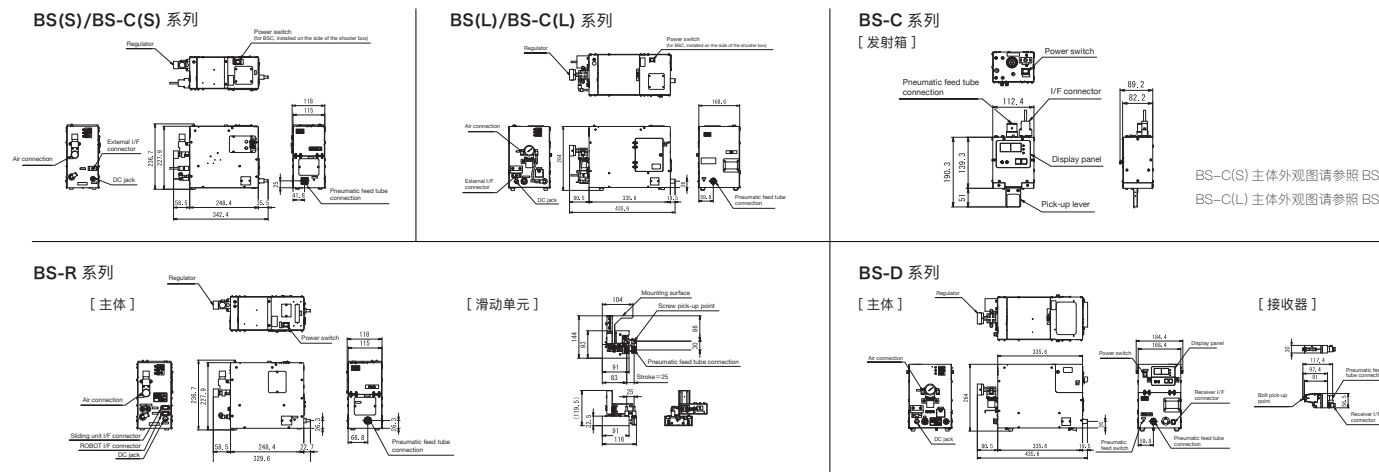

规格 Specifications

产品名称	BS-S	BS-L	BS-CS	BS-CL	BS-D	BS-P	BS-R	
外形尺寸	118(W)×310(D)×237(H)	169(W)×436(D)×270(H)	118(W)×310(D)×237(H)	169(W)×436(D)×270(H)	169(W)×436(D)×270(H)	175(W)×304(D)×186(H)	118(W)×310(D)×237(H)	
质量 (含轨道)	约 4kgf	约 10kgf	约 5kgf	约 12kgf	约 12kgf	约 4kgf	约 4.6kgf	
电源	AC100V ~ 240V DC15V 1A AC 适配器							
空气	0.5MPa MAX 400L/min							
主体驱动马达	直流有刷电机							
螺丝压送方向	←						←	
超载保护与回复电路	○	○	○	○	○	○	○	
外部界面	○ (D-SUB 9pin)	○ (D-SUB 9pin)	-	-	-	○ (D-SUB 9pin)	○ (D-SUB 9pin)	
工序节拍时间	M6X25/3M 通过输送管约需 2 秒						约 1.2 秒	约 1.5 秒
适用螺丝直径	M2.0 ~ M6.0				M3.0 ~ M6.0	M1.0 ~ M3.0	M2.0 ~ M5.0	
适用螺杆长度	最长至 25mm				15~25mm	最长至 12mm	最长至 14mm	
适用螺丝全长	全长 / 头径 = 1.3 以上							
螺丝容量	约 280cc	约 1300cc	约 280cc	约 1300cc	约 1300cc	约 80cc	约 280cc	
附属品及随附品	使用说明书 / AC 适配器 / 六角扳手 / 调整用螺丝刀 / 地线 / 压送管 (2.5M)							

附属单元	-	-	发射装置 外形：113(W)×82(D)×140(H) 容量：M6X25 约 20 根	接收器 外形：30(W)×52(D)×120(H)	-	滑动单元 外形：116(W)×144(D)×120(H)
------	---	---	---	------------------------------	---	---------------------------------

* 订购前请务必咨询。 *Please inquire before placing an order.

为保证螺丝供料机长时间运行

Enables Long-Running Screw Feeding

螺丝料仓

Screw Hopper

传感器检测螺丝供料机内的螺丝数量，自动供给最适宜的螺丝量。

A sensor detects the screw stock to automatically feed the optimal amount of screws. Use this to make operation easier.

适用螺丝直径 M1.0~M6.0	适用螺丝全长 最长 18/25mm	容量 约 400cc~1600cc	铁制螺丝专用 For iron screws 非铁制可 Non-ferrous materials supported
---------------------	----------------------	-----------------------------	--

* 详细内容参考产品规格书。
For details, please refer to each product's specifications.



SR-80 / NJ-80 叶轮式 后方安装型

Rear-attaching Impeller Type

- 只需与螺丝供料机并排摆放即安装完毕。不占上部空间。
- 超小型不占地方，但仍有 800cc 的存放量。
- 可用计时器设定叶轮的运行时间。

- Easy installation—simply line it up next to the screw feeder. It will not take up space on the upper surface.
- Super compact model fits anywhere, yet has room for a screw stock of 800cc.
- Use the timer to set the impeller's operation time.

产品型号 Compatibility Table

SR-80 型	对应螺丝供料机	NJ-80 型	对应螺丝供料机
品号		品号	
SR-80	NSB / NSR / NSBI / NSRI / NSRI-B	NJ-80	NJ / NJR
		NJ-80F	FM-36 / FME-36

800cc 根据螺丝直径长度可存放数量 / M2.3x5 约 20,000 根 M3.0x6 约 5,600 根
Stock capacity based on the diameter and length of the screw for 800cc: M2.3 x 5, approx. 20,000; M3.0 x 6, approx. 5,600



RHP-160 叶轮式大容量 侧面、后部安装型

Side and Rear Attaching High-Capacity Impeller Type

- 只需与螺丝供料机并排摆放即安装完毕。
- 可存放 1600cc 的螺丝。
- 可用计时器设定叶轮的运行时间。

- Easy installation—simply line it up next to the screw feeder. It even supports long screws.
- Supports a screw stock of approximately 1600cc.
- Use the timer to set the impeller's operation time.

产品型号 Compatibility Table

RHP-160 型	对应螺丝供料机
品号	
RHP-160J	NJ / NJR
RHP-160F	FM-36 / FME-36
RHP-160M	OM-26M / OM-26R / OM-26RB



T-510 传送带式 上部安装型

Conveyor Style, Surface Mounting Type

- 只需放置在螺丝供料机上部即安装完毕。
- 可垂直叠放增加存放数量，不占地面空间。
- 可用计时器设定传送带的运行时间。

- Easy installation—simply align it on top of the screw feeder.
- Does not take up floor space; allows you to add more stock vertically.
- Use the timer to set the conveyor belt's operation time.

产品型号 Compatibility Table

T-510 型	对应螺丝供料机
品号	
T-510S	NSB / NSR / NSBI / NSRI / NSRI-B
T-510J	NJ / NJR
T-510F	FM-36 / FME-36

400cc 根据螺丝直径长度可存放数量 / M2.3x5 约 10,000 根 M3.0x6 约 2,800 根
Stock capacity based on the diameter and length of the screw for 400cc: M2.3 x 5, approx. 10,000; M3.0 x 6, approx. 2,800



MHP-80 磁铁式 后部安装型

Magnetic Style, Rear-Attaching Type

- 只需与螺丝供料机并排摆放即安装完毕，也可支援长螺丝。
- 通过磁力输送供给螺丝。
- 可用计时器设定磁铁的运行时间。

- Easy installation—simply line it up next to the screw feeder. It even supports long screws.
- Magnets are used to feed and convey screws.
- Use the timer to set the magnet operation time.

产品型号 Compatibility Table

MHP-80 型	对应螺丝供料机
品号	
MHP-80S	NSB / NSR / NSBI / NSRI / NSRI-B
MHP-80J	NJ / NJR
MHP-80F	FM-36 / FME-36
MHP-80M	OM-26M / OM-26R / OM-26RB

外观图

Model Diagrams

* 各机型的外观图可从网站下载。
Full diagrams of each model can be downloaded from our website.

SR-80 型

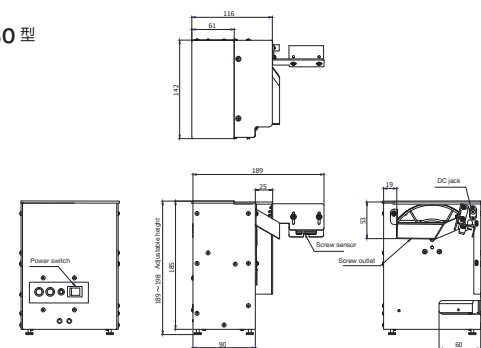

RHP 型

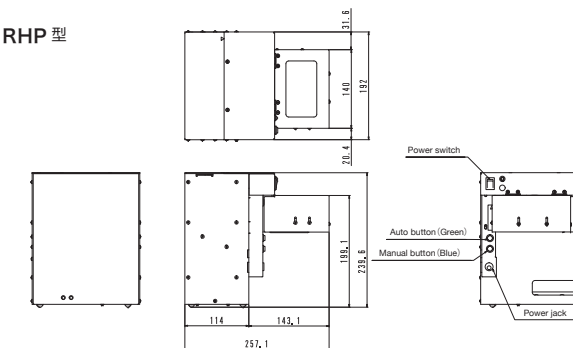

NJ-80 型

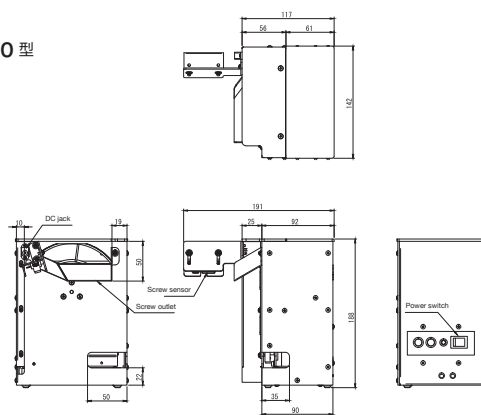

MHP 型 (MHP-80M)

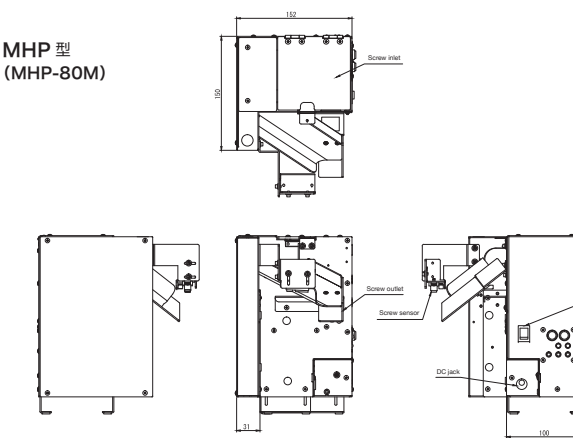

T510 型

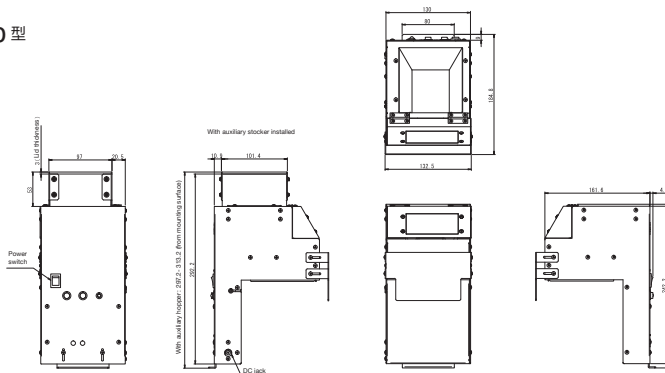

规格 Specifications

产品名称	NJ-80	SR-80	T-510	RHP-160	MHP-80
外形尺寸	142(W)×191(D)×188(H)	142(W)×191(D)×189~198(H)	130(W)×171(D)×245(H) 安装辅助储存库时 295(H)	192(W)×237(D)×240(H)	156(W)×150(D)×212(H)
质量 (含轨道)	约 2.9kgf		约 3.1kgf	约 5.5kgf	约 2.9kgf
电源	AC100V~240V DC15V 1A AC 适配器			AC100V~240V DC15V 1A AC 适配器	
主体驱动马达	直流有刷电机				
外部输出信号线 (余量传感器)	-	-	○	-	○ (带余量传感器是选装)
安全功能	-	-	-	储存库盖打开时停止动作	-
适用螺丝材质	-	-	-	-	只限铁制
适用螺丝直径	M2.0~M6.0		M1.0~M6.0	M2.0~M6.0	M2.0~M6.0
适用螺杆长度	最长至15mm(全长至18mm)			最长至 25mm	
螺丝容量	约 800cc		主体 约 400cc 增设储存库 约 400cc	约 1600cc	约 800cc
附属品及随附品	使用说明书 / AC 适配器 / 防螺丝飞散盖 / 设置台与安装螺丝 (仅限 NJ-80F)		使用说明书 / 增设储存库 / AC 适配器 / 六角扳手 / 螺丝 (M2.6×5) / 外部输出信号线 / 设置台与安装螺丝 (仅限 T-510F)	使用说明书 / AC 适配器 / 六角扳手 / 设置台与安装螺丝 (仅限 RHP-160F)	使用说明书 / AC 适配器 / 防螺丝飞散盖 / 调整用螺丝刀 / 设置台与安装螺丝 (仅限 MHP-80F)

FAQ

常见问题

Q 想要增加供料机螺丝的容量 Can I increase the capacity for the screw feeder?	增设螺丝料仓后可增加 400 ~ 1600cc 的容量。 You can add a screw hopper to add a capacity of 400~1600cc.
Q 自攻螺丝流动不佳 Self-tapping screws are not working as intended. Why?	例如，有可能 M3.0 的自攻螺丝里混杂了 M3.5 的螺丝。如果用在公差偏差较大的工件，请根据螺丝 / 螺栓的最大直径选择产品。 One possible cause is that M3.5 tolerance screws are intermingled with M3.0 tapping screws. If you are handling workpieces with large differences in screw tolerance, select a product based on the maximum screw and bolt diameter.
Q 想使用六角孔螺栓 I want to use a hexagon socket head cap bolt.	如果想使用六角孔螺栓，请在订购前咨询代理店。 If you are considering a hexagon socket head cap bolt, please make an inquiry with our dealer before placing an order.
Q 想要外观图 Can I have model diagrams?	各机型的外观图可从本公司网页下载。 They can be downloaded from our website.
Q 是否适用特殊形状的螺丝和螺栓 Do you support special screw and bolt shapes?	如需本公司研讨针对使用特殊形状的螺丝和螺栓等的可行性，请从本公司网页打印《特制研讨委托书》，填写好必要事项后，提交至本公司代理店。 If you are considering a device for a specialized screw or bolt, please print out the Special Order Form from our website, complete it, and submit it to one of our dealers.
Q 想要维修零件 Can I have extra parts for maintenance?	如需购买维修零件，请联系购机代理店。 Yes, they can be downloaded from our website.
Q 有关自动机的固定方法 How can I fix a feeder for a robotic device?	请参阅本公司网页的《产品使用说明书》。 This is described in the product manual available on our website.
Q 欲知更多选装零件 I want to know more about options.	请浏览本公司网页。 Please refer to our website.

关于可通过信号线输出的信号

Signals obtained from signal line

- 手动型：能够输出螺丝取出时的信号。
- 机器人（自动）型：能够输出螺丝取出部有无螺丝的信号。
- 定量取出型：能够输出设定数量螺丝已供给完毕的信号。

- Manual models: Signal of the screw pick up can be obtained.
- Robotic models: Signal of whether there is a screw in the screw pick-up point can be obtained.
- Fixed quantity pick up models: Signal of feed completion for set number of screws can be obtained.

委托修理的用户

For customers seeking repairs

请从本公司网页打印维修委托书，填写好必要事项后，委托购机代理店进行维修。需维修的机器需要随附维修委托书。如无法打印，请将填写好右述内容的纸张，与需维修的机器一同交给购机代理店。

Print out a repair request form from our website, complete it, and submit it to the dealer where you purchased the product.

Include the same document with your item to be repaired.

If you do not have a printer, please include the details indicated on the right on a piece of paper.

网页：www.ohatake-root.co.jp

- 产品名称
- 序列号（机器背面）
- 公司名称、地址、负责人所属部门及姓名、电话号码、传真号码
- 故障状况（请详细填写）
- 使用环境（所使用的螺丝等）

- Product name
- Serial number (on rear)
- Company name, address, contact person's name and department, telephone number, fax number
- Problem (in detail, and please be as specific as possible)
- Context in which it was used (type of screws, etc.)

自动螺丝供料机/螺丝料仓AC 适配器插头形状列表

Automatic screw feeder/Hopper AC adapter plug formats

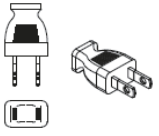
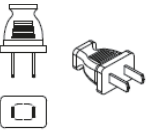
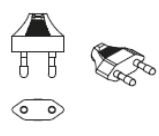
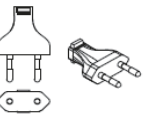
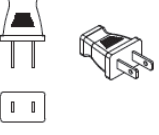
对象机种	直流电压	适配器型号	AC 电源线种类	(代表)对象国家	适配器形状	插头形状
全部机型	DC15V	UNI315-1510	PSE线	日本 墨西哥 巴西 其他	电源适配器： 适用各国认证电源线 (100-240V AC)	A型式 PSE (日本) 认证 (~AC125V) 
		UI315-15	CCC线	中国 泰国 台湾 马来西亚 越南 巴西 其他		A型式 CCC (中国) 认证 (~AC240V) 
			KC线	韩国	SE型式 KC (韩国) 认证 (~AC240V) 	
		UNI315-1510	CE线	EU 各国 阿根廷 印尼 印度 越南 其他	电源适配器： 适用各国认证电源线 (100-240V AC) (50/60 Hz)	C型式 CE (EU) 认证 (~AC240V) 
		UNI315-1510	UL线	美国		A型式 UL (美国) 认证 (~AC125V) 

*为适配器与AC 电源线分体型。

以下适配器与2020年3月之前制造的螺丝料仓兼容。检查螺丝料仓主机铭牌上的电压。

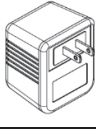
对象机种	直流电压	适配器型号	AC 电源线种类	(代表)对象国家	适配器·插头形状
螺丝料仓 SR-80 NJ-80 T-510	DC12V	AD-1200 500DJ	100V 适配器	日本	A型式 PSE (日本) 认证 (AC100V 50/60 Hz) 
		YL41-12000 500D	Sales of YL41-12000500D within the EU have been discontinued. As an alternative, we will sell the adapter UNI315-1510 for DC15V and the conversion cable HSC09024. Please contact the distributor where you purchased the product.		

※ DC12V 为适配器与AC 电源线一体型。上述以外的附件需由客户自行准备。

“Quicher”是株式会社大武・ルート工业的注册商标。

*“Quicher” is a registered trademark of OHTAKE-ROOT KOGYO CO., LTD.

注意 Caution

●本目录登载的产品规格和性能数值是根据本公司的设计计算与公司内试验、性能单独评定制品的使用实绩和官方规格得出的数据或规格，选择机型时参考的数值仅供在一般条件下使用。

●本目录的登载事项可能会在未事前通知的情况下因内容的补充、改善及设计变更等而做修改。

●如在特殊条件下使用该产品，需事前就技术性内容与本公司协商或尽使用者之责任进行性能验证和评估。如未经此程序发生财产损失或人身伤亡，本公司将不会承担任何责任。

●为了安全使用本产品，使用前请务必阅读《使用说明书》。

●The specifications and performance figures of the products described in this catalog are based on our company's design calculations, in-house testing, individual performance testing, product usage results, and official standards/specifications. These are provided for reference purposes only for model selection under normal circumstances.

●The items listed in this catalog may be amended, have their designs changed, or be revised without notice.

●If you are considering using our products under special circumstances, please make sure to discuss technical issues with us beforehand, or conduct a test and evaluation to check the performance on your own responsibility. If damages or injuries are incurred without following this process, OHTAKE-ROOT KOGYO cannot be held responsible.

●For safe usage of our products, please make sure to read the instruction manual before using them.