

Automatic Screw Feeder

自動ネジ供給機

FM-36 Series

Operation manual (Maintenance)

- Read these instructions for the proper use of this machine.
- After having read these instructions, keep them in a convenient place so you or the operator can refer to them whenever necessary.

ATTENTION : www.ohtake-root.co.jp is the only web site associated with our company.
We do not have any branches in China.

各位顾客请注意! : 「www.ohtake-root.co.jp 是敝司唯一的官方网站,
目前, 敝司在中国没有办事处与所谓的中国官网。」

注意! : www.ohtake-root.co.jp が当社唯一の HP アドレスです。
弊社の名を騙る偽サイトにご注意下さい。現在、当社は中国国内に支店はございません。

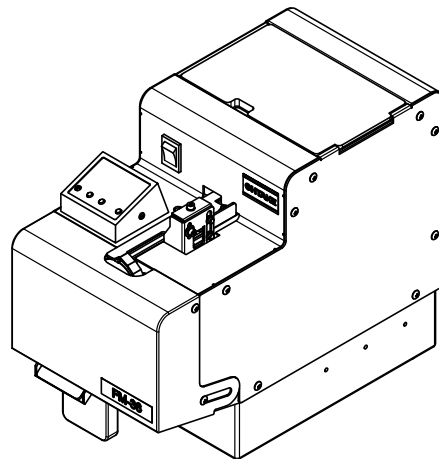

FM1MAE02bm

Contents

1. OVERVIEW OF THIS MACHINE -----	1	8. MAINTENANCE-----	17
2. BEFORE USE -----	1	9. REPLACING PARTS-----	18
3. OPERATING PRECAUTIONS -----	2	10. TROUBLESHOOTING-----	20
4. NAMES OF MACHINE PARTS -----	7	11. SPECIFICATIONS -----	25
5. ADJUSTMENTS AND CHECKS BEFORE USE-----	8	12. EXTERNAL DIMENTIONS-----	27
6. OPERATING INSTRUCTIONS-----	12	13. WARRANTY -----	28
7. EXTERNAL OUTPUT SIGNALS-----	16		

1. OVERVIEW OF THIS MACHINE

Thank you very much for selecting our Automatic Screw Feeder "FM-36 series ".

This product can align the M3 to M6 screws and take out the set number, which helps manage the number of screws.

Different sizes of screws can be used by changing the rail, escaper unit and passage plate. It can be used wherever there is a power source for an AC adapter.

2. BEFORE USE

Please check for the following accessories before operating the machine.

- | | | | |
|----------------------|---------|---------------|---------|
| * Instruction Manual | 1 copy | * AC Adapter | 1 unit |
| * Hexagonal Wrench | 1 piece | * Screwdriver | 1 piece |
| * Ground wire | 1 piece | | |

* The design, performance and specifications are subject to change without prior notice for the sake of improvement.

3. OPERATING PRECAUTIONS

This manual contains safety alert symbols and signal words to help prevent injuries to the user or damage to property.

◎ Indications



WARNING

This indicates there is a chance of death, serious injury or fire if the instructions are not followed.



CAUTION

This indicates there is a chance of personal injury or damage to property if the instructions are not followed.

◎ Symbols indicating type of danger and preventative measures



Prohibited operation. Never do this!



Do not disassemble, modify or repair.



Do not touch with wet hands.



This indicates to stop operations.



Unplug power supply from wall outlet.













General caution.

Attach the ground wire by loosening the screw near the mark  of the equipment.















the bottom of the main body

WARNING

-  Do not disassemble the AC adapter as there is a risk of electric shock, fire or malfunction.
-  Do not damage, alter or change the power cord. Do not place heavy objects on the cord.
 Do not pull hard on the cord or twist the cord as it could be damaged, thereby causing a risk of fire or electric shock.
-  Do not handle the AC adapter with wet hands as it could cause an electric shock.
-  When using an outlet with AC100 ~ 240V, don't overload the electrical circuit.
 Do not modify or remodel this machine as this may cause a fire or electric shock.
-  Do not operate this machine near flammable liquids, gasses or materials as there could be a risk of fire or explosion.
-  Stop operating the machine and unplug the AC adapter from the wall outlet when you detect overheating, smoke, a pungent odor or any other unusual condition, as there may be a risk of fire or electric shock. Contact the dealer, from which you purchased the machine, and have it examined and repaired.
-  In the case of a thunderstorm, stop operating the machine, turn off the power and unplug the AC adapter from the wall outlet. If there is lightning and thunder nearby, move away from the machine and do not touch it or the AC adapter.
After the thunder stops, and when it is safe to do so, check the machine. If there is any abnormality, contact your dealer.
-  When performing maintenance, changing parts or when you sense an abnormality in the machine, turn the power off and pull the AC adapter from the wall outlet.
In addition, there are parts that become hot in the circuit board. When performing maintenance around the circuit board, turn off the power for at least 5 minutes before performing work. There is a risk of burns.

CAUTION

-  Use only the AC adapter supplied with this machine otherwise it may result in a fire or electric shock.
-  Do not install this machine in an unstable location otherwise it may fall causing damage or injury.
-  Always operate the machine with the upper cover in place, otherwise it may result in injury.
-  Do not allow any foreign material to enter the machine while in operation.
 Do not put your fingers into the machine while in operation, otherwise an injury will result.
-  Do not operate this machine in overly humid or dusty conditions.
Keep the socket plug clean at all times otherwise it may cause a fire or electric shock.
-  When moving the machine, always disconnect the AC adapter from the wall outlet or it may result in damage to the cord, or cause a fire or electric shock.
-  Turn off the machine and unplug the AC adapter from the wall outlet during closing hours or if the machine will be unused for any extended period of time.
-  When moving the machine, be sure to hold it with both hands and be careful not to drop it. Dropping the machine at your feet may cause injury.
-  Do not operate the machine with tension on the AC adapter cord.
Keep the cord loose and untangled.
-  Do not bend, alter or damage the rail. Do not apply any oil. It is recommended that the user clean the rail periodically.
-  Do not use any screw that is out of the specified range nor any screw that is oily or dirty.

Note : About the screws stock limit

CAUTION !

If too much screws are placed into the storage chamber of the feeder, it may affect the process of screw feeding, or cause the machine to be overloaded and malfunction.

Please refer to the diagram below and carefully adjust the screw level to be 2 ~ 3mm below upper edge of the rail.
(When the scoop plates are at the lowest point.)

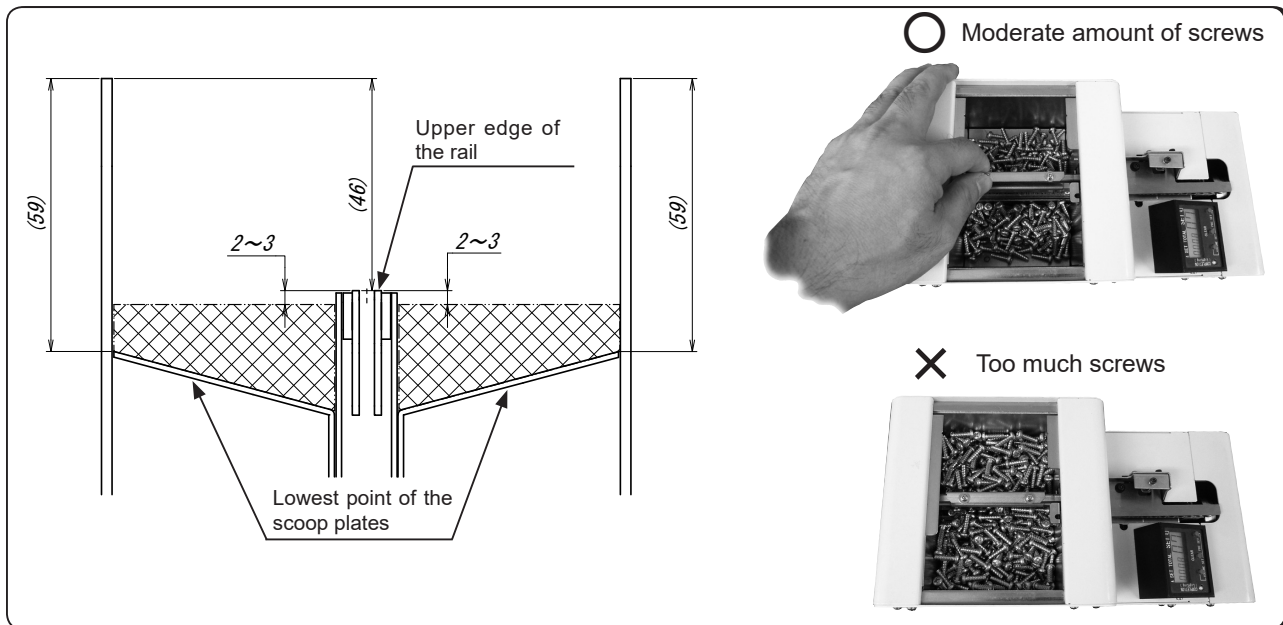

Precautions in Ejecting Screws

Please use maximum care in ejecting screws from the Screw bin for changing screw types, replacing the rail and so forth.

- Ⓢ Screws could fall into the inside of this machine if ejection is mishandled.
- Ⓢ If this machine is tilted or turned back with screws being accumulated at the unloading port or left on the rail, screws may fall into the inside of this machine.
- Ⓢ Unload screws from the unloading port and move all screws from the rail to the screw bin, take them from the chamber.
- Ⓢ See the illustrations below for ejecting screws. Use maximum care in ejecting screws from the screw bin not to let them fall into the inside of this machine.

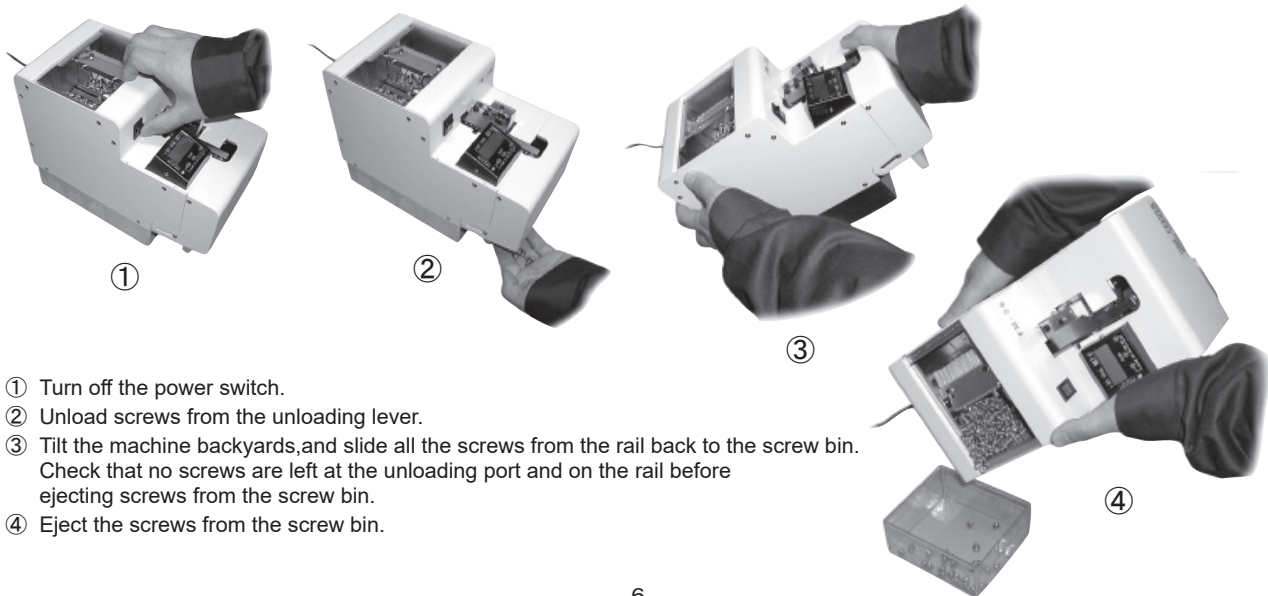

- ① Turn off the power switch.
- ② Unload screws from the unloading lever.
- ③ Tilt the machine backwards, and slide all the screws from the rail back to the screw bin. Check that no screws are left at the unloading port and on the rail before ejecting screws from the screw bin.
- ④ Eject the screws from the screw bin.

4. NAMES OF MACHINE PARTS

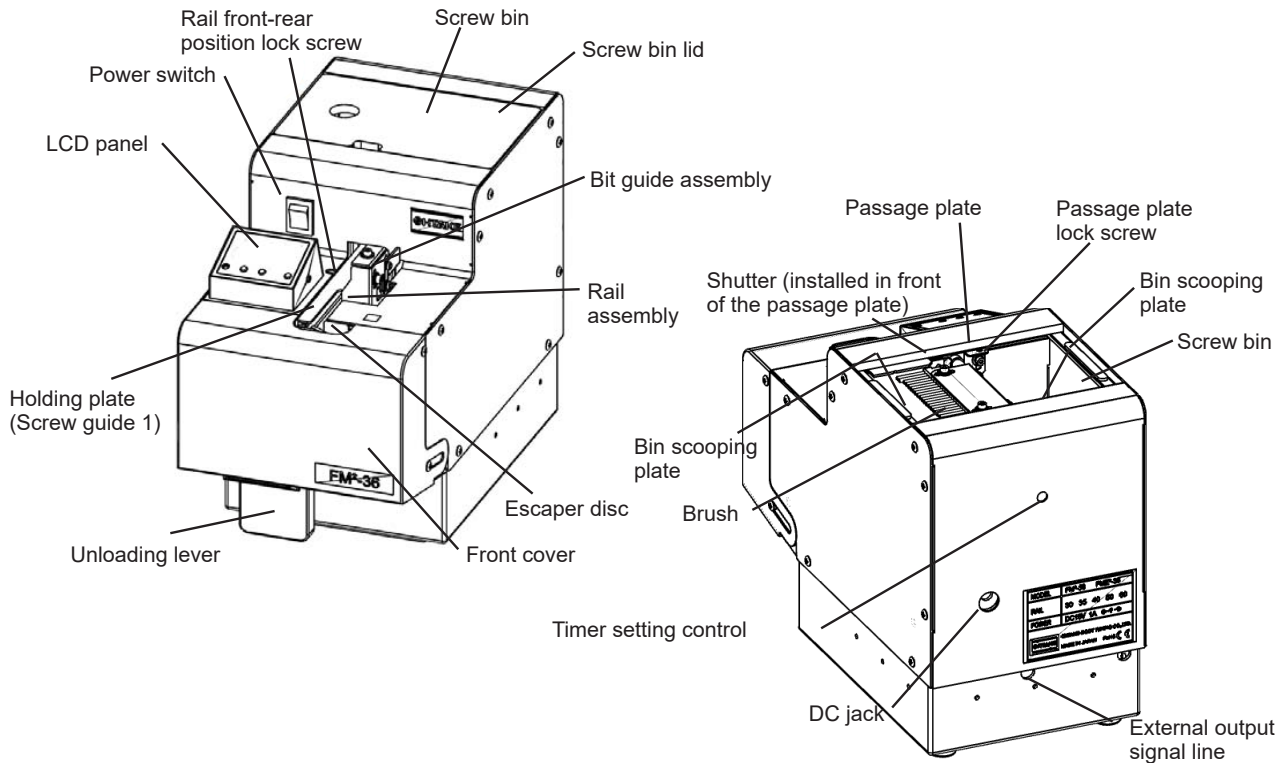

5. ADJUSTMENTS AND CHECKS BEFORE USE

Before using this machine, check to make sure that the nominal diameter of the applied screw meets the unit type. To identify the unit type, remove the front cover and the rail assembly and look at the labels affixed to the rail assembly and the Escaper Unit.

This machine can be customized to screws of different sizes by replacing the rail assembly and the Escaper Unit.

Type	Model number	Screw nominal diameter	Exchange Kit number	Rail model number	Escaper Unit model number	Passage plate model number
FM-36	FM-3630	φ3.0	FR30SET	FR30	F30	W3630
	FM-3635	φ3.5	FR35SET	FR35	F35	W3635
	FM-3640	φ4.0	FR40SET	FR40	F40	W3640
	FM-3650	φ5.0	FR50SET	FR50	F50	W3650
	FM-3660	φ6.0	FR60SET	FR60	F60	W3660

This machine ships factory-adjusted to handle pan-head screws. If this machine requires adjustment to meet the kind of screw to use, make the following checks and adjustments beforehand:

- Brush check and adjustment
- Passage plate check and adjustment
- Holding plate check and adjustment for height of screw
- Rail assembly and Escaper Unit check and adjustment

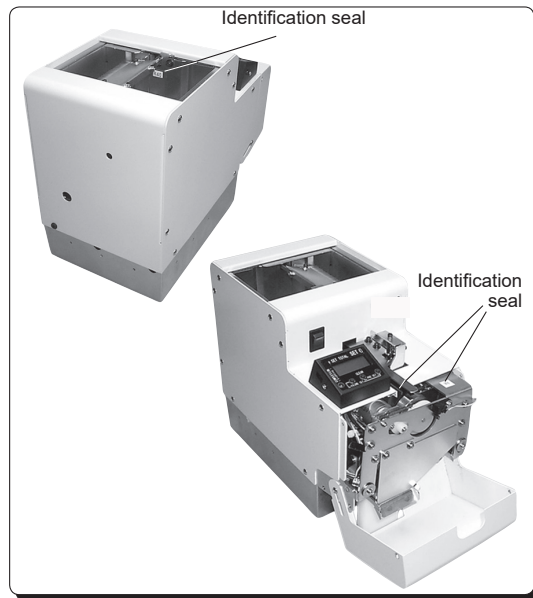

5.1 Brush Check and Adjustment



CAUTION

Turn off the power switch before performing check and adjustment work.

Put a screw to use in the screw bin and turn the power switch on, then off to place the screw into the rail groove.

- Turn the power switch on, then off to keep the brush roughly level as shown at right.
- Check that the tip of the brush swipes above the head of the applied screws placed in the rail groove.
- The alignment and transfer of screws would be adversely affected if the brush is positioned too high or too low.
- If the brush requires adjustment, loose the brush height adjustment screws.
- If the front of the plastic part of the brush hits the passage plate, loosen the brush assembly mounting screw and adjust its longitudinal position.
- Run this machine to check that the brush works correctly.

5.2 Passage Plate Check and Adjustment



CAUTION

Turn off the power switch before performing check and adjustment work.

- Check that the passage plate is adjusted at such height that allows the applied screw to pass barely.
- Too low a passage plate would not allow screws to pass, and too high a passage plate would make screws more liable to stop delivery.
- If the passage plate requires adjustment, loose the passage plate mounting screw.
- When the adjustment is complete, verify correct operations.

Turn the power switch on, then off to keep the brush roughly level.



Moving the brush by hand, check that the tip of the brush rubs on the head of the Applied screw placed in the rail groove.

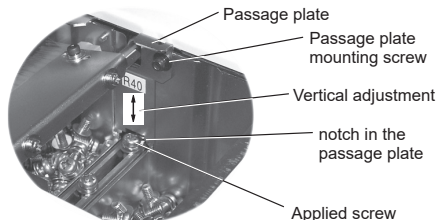
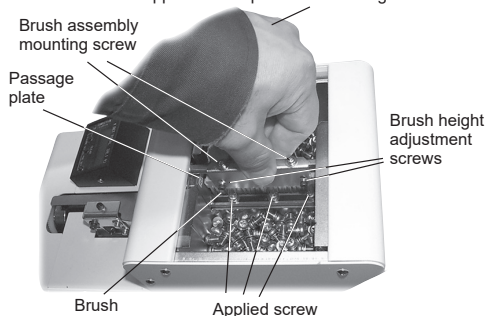

Check that the passage plate is adjusted at such height that allows the Applied screw to pass barely.

5.3 Holding Plate Check and Adjustment

Check the Holding plate position.

- Without a clearance between the head of the applied screw in the rail groove and the Holding plate, screws could be stuck. Too large a clearance could cause screws to overlap or cause them to pop out and fall into the machine.
- If the Holding plate requires adjustment, please do so by the following;

(1) Vertical adjustment of the Holding plate

- Loosen the bit guide assembly setscrew and turn the bit guide assembly vertical adjustment screw.
- Make adjustments for a clearance of about 1 mm between the head of the applied screw.
- Clamp the bit guide assembly setscrew. When the adjustment is complete, verify correct operations.
 - Screws on the rail are delivered smoothly.
 - Screws do not fall out from the rail.

(2) Adjustments for a clearance between Escaper disk and Extended part of Holding plate

- Loosen the Holding plate setscrews.
- Move the Holding plate to right and left, so that clearance H1 and H2 of the right figure become about the same.
- Fasten the Holding plate setscrews. When the adjustment is complete, verify correct operations and no troubles occur.
- When the applied screws are put on the groove of the escaper disk, turned the escaper disk to the right side by hand
 - A screw does not get stuck by Holding plate when the escaper disk turns.
 - A screw does not fly out from the escaper disk.

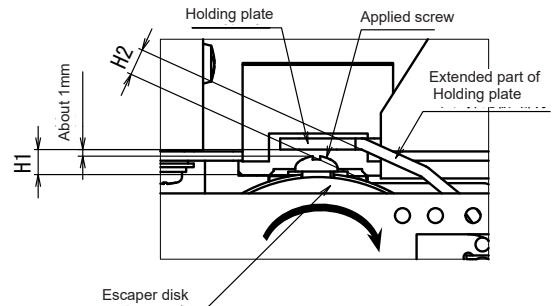
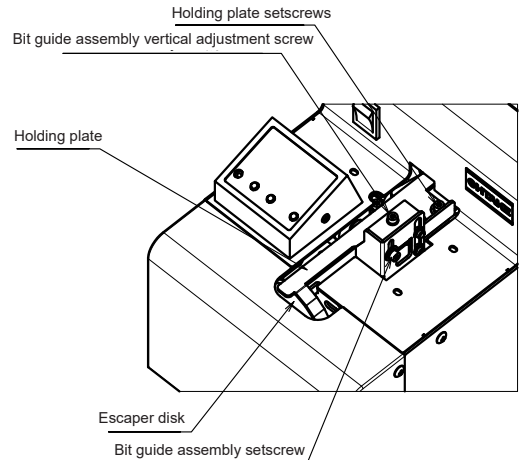

5.4 Check and adjust the rail position

- Make sure that the clearance between the rail and the escaper disk is appropriate.
- When the gap is large, the screw falls and causes erroneous count. Ideally, the gap should be as small as possible.
- If the tip of the rail is in contact with the escaper disk, it prevents rotation of the disk. It may cause an erroneous count.
- It is usually adjusted at the time of shipment, but if adjustment is necessary Loosen the front and rear fixing screw of the rail and adjust it.
- Adjust the rail position so that the tip of the rail does not hit the escaper disk when the power is turned on and the rail vibrates.
- After adjustment, please be sure to tighten the rail fixing screw.

Rail fixing screw



Please adjust the gap as small as possible within the range where the tip of the rail does not hit the escaper disk due to rail vibration.

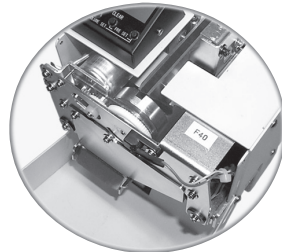
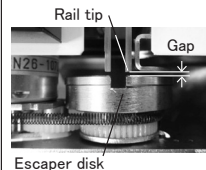

5.5 Timer Check and Adjustment

The applied screw transfer speed varies depending on the screw type. A longer timer interval setting is recommended for screws with a lower transfer speed, and a shorter timer interval setting is recommended for screws with a faster transfer speed.

- This machine is designed to halt screw transfer with a certain delay after a certain count of screws has accumulated at the unloading port. This delay can be adjusted with the timer.
- A Timer setting control screw is found in the rear of this machine as shown at right.
- Turn the trimmer clockwise when this machine is viewed from the rear to decrease the interval or counterclockwise to lengthen the interval.
- Adjust the trimmer within the range of its rotation, without using undue force.
- Use the provided screwdriver for adjusting the trimmer.
- Set an appropriate timer interval by verifying a correct this machine operation on applied screws.

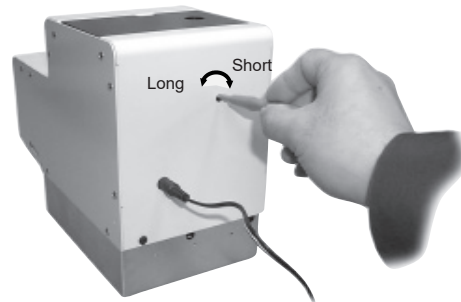

6. OPERATING INSTRUCTIONS

6.1 Supply of Screws



CAUTION Loading this machine with too many screws could adversely affect their alignment and transfer.

The approximate maximum supply of screws is illustrated in the figure at right. Consult this figure for loading screws.

- Turn the power switch on, then off to move the Bin scooping plate to the lower position.
- Load screws to a roughly 2 to 3 mm lower than the top surface of the rail groove. Check to make sure that the top surface of the rail groove is not covered by the screws.
- Adjust the supply of screws by observing behavior of this machine in operation.

This machine comes with an overload protection circuit.

The protection circuit trips when the moving parts of this machine are overloaded, such as when screws being stuck in the moving parts, or too many screws being put in the screw bin.

Actuation of the overload protection circuit

If the moving parts of this machine are overloaded, the drive motor reverses for a predetermined period of time and then returns to forwarding. When the overload imposed on the moving parts of this machine no longer exists during reversing, the drive motor returns to normal forwarding. If the overload imposed on the moving parts of this machine persists during reversing, the drive motor reruns the sequence of reversing, forwarding, reversing, forwarding and so forth for a predetermined period of time before it is powered off. The escaper disc continues operating, though.

Thus explained, if the drive motor is powered off, turn off the power switch and remove the overload imposed on the moving parts of this machine. For example, if you have put too many screws in the Screw bin, correct the supply of screws. If screws or any other objects are stuck in the moving parts of this machine, remove them.

After the overload has been removed, turn on the power switch to put this machine back into operation (power-on reset).

- A screw stock option, NEJIKURA is available which loads screws automatically to maintain the supply of screws. Please check with your dealer if you need this option.

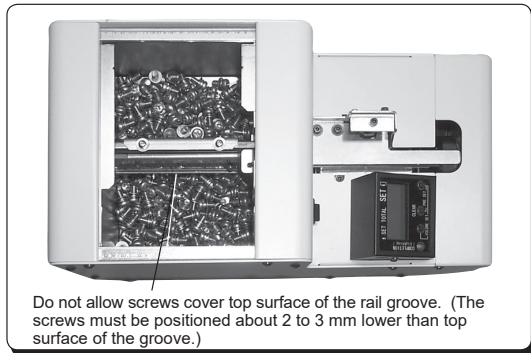

Do not allow screws cover top surface of the rail groove. (The screws must be positioned about 2 to 3 mm lower than top surface of the groove.)

Unit with the floor-type
(NJ-80) NEJIKURA installed

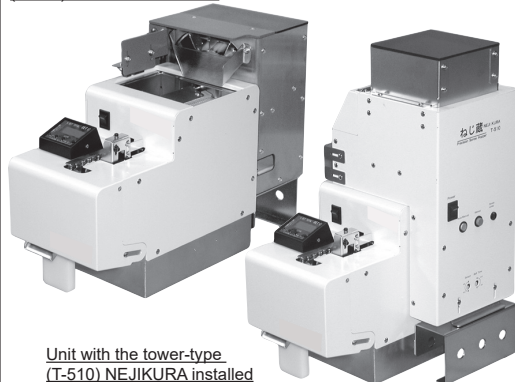

Unit with the tower-type
(T-510) NEJIKURA installed

6.2 Unloading Screws

This machine ships factory-adjusted with handle pan-head screws. This machine should require the following checks and adjustments depending on the kind of screw to use:

- LCD panel setting change
 - Brush check and adjustment
 - Passage plate check and adjustment
 - Holding plate check and adjustment
 - Rail assembly and Escaper Unit check and adjustment
-
- When the power switch is turned on, the Bin scooping plate moves up and down for a predetermined period of time and then stops.
 - Push in the unloading lever to start this machine.
 - When a preset count of screws has accumulated at the unloading port, the LED lights up, the buzzer sounds, and this machine halts with a certain delay.
 - Push in the unloading lever to unload the preset (metered) count of screws and the LED goes out, with this machine restarting.
 - If you push the unloading lever before a preset count of screws is stored, the LED blinks and the buzzer continues sounding. This machine then starts recounting the preset count of screws after a period of time.
 - Push the unloading lever forward until it hits the stopper. The LCD panel LED does not go out and this machine does not restart unless the unloading lever makes full contact with the stopper.

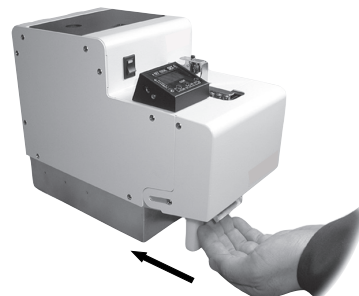

While the LCD panel LED is on, push the unloading lever forward until it hits the stopper.

Screws will drop onto your palm at the same time.

This machine, when just powered on, behaves differently depending on the state in which it had been powered off. This machine won't start unless you push the unloading lever.

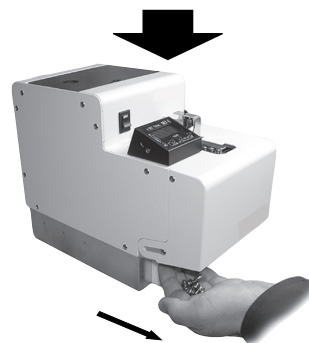

Return your hand to front with care not to drop the screws off your palm.

The LCD panel LED goes out and this machine restarts.

6.3 LCD Panel Indicators and Settings

◎ LCD Panel Indicators

<Preset count indicator>

- Shows a preset count of screws.
- Decrements each time a screw is delivered to the unloading port.
- Is reset to the preset count when the preset count of screws has accumulated at the unloading port.
- Blinks while changes are being made to the preset count.
- Each time the preset count of screws has accumulated at the unloading port, this machine stops. When screws are unloaded from the unloading port, this machine restarts.

<Preset total indicator>

- Shows the total of preset counts of screws.
- Increments each time a preset count of screws are accumulated at the unloading port.
- Each time the count of screws has accumulated at the unloading port, this machine stops. When the screws are unloaded from the unloading port, this machine restarts.

<LED indicator>

- Lights up each time a preset count of screws has accumulated at the unloading port.
- Blinks when the unloading lever is manipulated while unloading a preset count of screws.
- Blinks while changes are being made to the sound volume.

<Setup buttons>

- Make changes to settings.
- The LCD panel indicators and settings are backed up by internal memory in times of power outages or when the power switch is turned off. When the power is restored, however, you need to manipulate the unloading lever to start this machine.

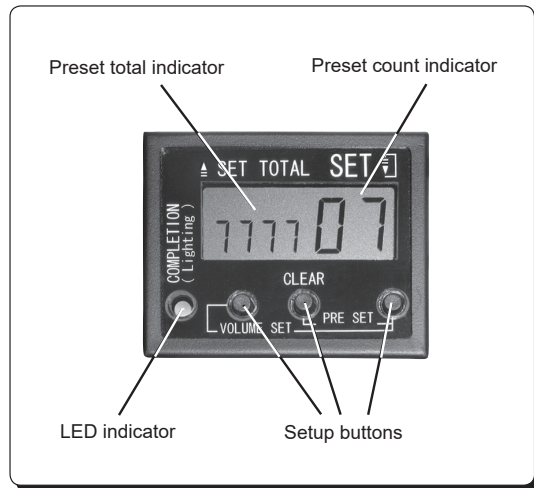

◎ LCD Panel Settings

LCD panel settings can be changed while this machine is shut down after it has been powered on.

<Clearing the preset total indicator → CLEAR>

- Press the CLEAR button for about 2 seconds, and the buzzer sounds and you can reset the preset total indicator to "0000."

<Changing a preset count → PRE SET>

- A preset count can be changed by resetting the preset total indicator to "0000."
- Press the right-side PRE SET button to change the first digit. Press the left-side PRE SET button to change the second digit.
- Continue pressing a PRE SET button and the buzzer sounds about 2 seconds later and, another 2 seconds later, the buzzer sounds again with the corresponding digit in the preset count indicator blinking.
- Press the PRE SET button once momentarily while the digit is blinking to change that digit.
- If you do not press the PRE SET button while the digit is blinking, that digit is set. The digit is also set if you press the other PRE SET button while the digit is blinking.
- Take out screws left at the unloading port after a setting change has been made and return them to the Screw bin.
- A preset count is up to 99.



CAUTION

A preset count is limited by the screw size and the capacity of the unloading port.

<Changing the sound volume → VOLUME SET>

- Press the VOLUME SET buttons for about 4 seconds at the same time and the LED blinks and you can change the sound volume.
- While the LED is blinking, press the right-side button once momentarily and the sound volume changes from medium to high, no tone, and low, back to medium and so forth.
- If you do not operate the buttons, the LED stops blinking and the sound volume then in effect is set.

<<CLEAR>>

Resets the preset total to "0000."

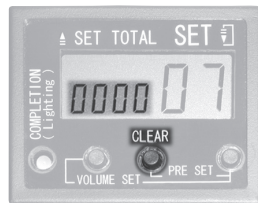

<<PRE SET>>

Sets a preset count.

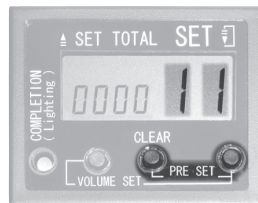

<<VOLUME SET>>

Sets a sound volume.

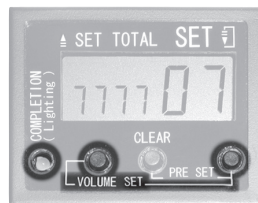

7. EXTERNAL OUTPUT SIGNALS

This machine has an external output signal line, allowing for external generation of a signal synchronized with the timing at which the LCD panel LED lights up, as an open collector output. Use this output to connect an indicator, buzzer or the like externally.

The signal line is housed inside this machine. To use the signal line, lead it outside through the grommet in the rear of the cover.

Purple line--->Signal line (Conducted when the LED is on)
 Gray line --->Common line

[Function]

When the LED is on • • • ON
 (When not ready for removal...OFF)
 (When ready for removal...ON)
 (Power ON / Error Ejection...
 LED blinking and synchronization)

Incoming current: shall be limited to less than 100mA

****CAUTION:** Additional resistor is required on external circuit for regulating current **

[Capacity]: Max DC current: 100mA

External supply voltage: 5 ~24VDC (Max: 27VDC)

[caution]:Please keep the length of output signal wire less than 3m.

* The purple wire functions as signal output high (Collector end), with the gray wire as common (Emitter end)

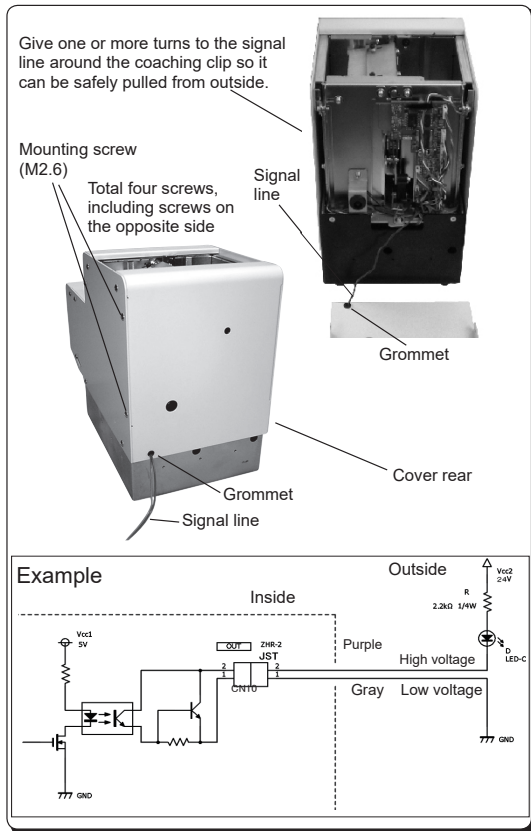

8. MAINTENANCE



CAUTION

Turn off the power switch before performing check and adjustment work.
Eject all applied screws from within this machine before proceeding with maintenance work.

A dirty rail groove could slow down the applied screw transfer speed. If the rail groove is found noticeably soiled, wipe it off with a thin cloth moistened with alcohol.

If the rail groove is difficult to clean, the rail can be detached from this machine for cleaning. Before detaching the rail from this machine, turn off the power switch and remove the screws from the Screw bin (to prevent screws from falling into the machine).

Remove two front cover mounting screws and move the front cover. Remove the Escaper Unit mounting screw and then detach the escaper disc.

(See 7.3, "Replacing the Escaper Unit.")

Then, loosen the Rail front-rear position lock screw and pull out the rail assembly to front.

The rail should require replacement if its rail groove is soiled or damaged to impair its function.

If the rail assembly has been removed from this machine, it is necessary to make positional adjustments with the tip of the rail and the escaper disc.

- Align the groove rail and the groove in the escaper disc with each other.
- Mount the Escaper Unit to keep the top surface of the groove in the escaper disc lower than the top surface of the rail groove.
- Turn on this machine and then make adjustments with the longitudinal position of the rail so its tip will not hit the escaper disc when the rail vibrates.

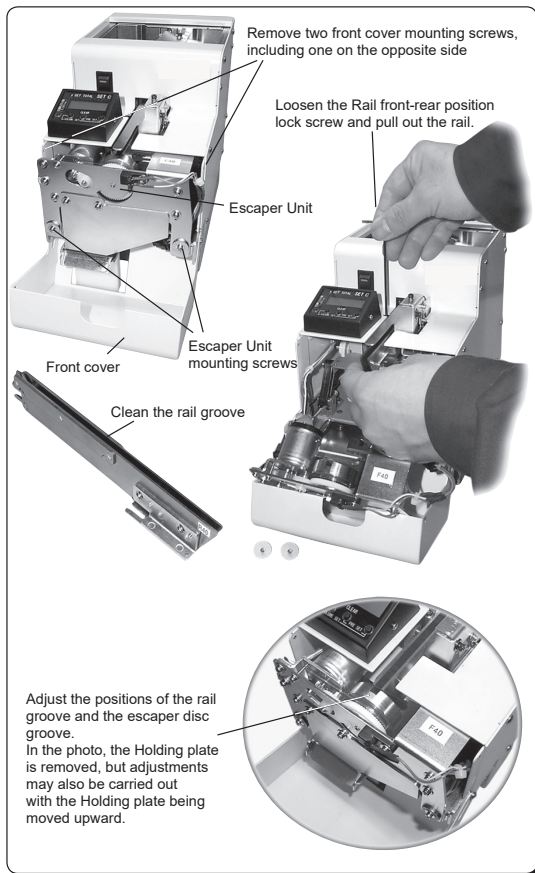

9. REPLACING PARTS

9.1 Replacing the Brush



CAUTION

Turn off the power switch before performing check and adjustment work.

If the tip of the brush has worn to such degree that the brush can no longer brush away screws in an abnormal posture, replace it with a new brush.

- Turn this machine power switch on, then off to position the brush as shown at top-right and then remove the brush assembly. (Have the brush assembly positioned to ease the work of removing the mounting screw.)
- The brush assembly can be disassembled as shown at right.
- To reassemble the brush assembly, reverse the removal procedure.
- When the reassembly is completed, check to make sure that the front of the plastic part of the brush won't hit the passage plate when the brush assembly operates. A ideally clearance of 0 is recommended.
- For adjustment instructions, see 5.4, "Brush Check and Adjustment."

9.2 Replacing the Passage Plate



CAUTION

Turn off the power switch before performing check and adjustment work.

When using screws of different nominal diameters, replace the passage plates for both the rail assembly and the Escaper Unit.

- Remove the Passage plate lock screw and then remove the passage plate.
- Keep the setscrew in a safe place.
- Install the passage plate in position with reference to the drafts on its both sides.
- After the adjustment, the passage plate requires adjustment to meet the kind of screw to use.

For adjustment instructions, see 5.5, "Passage Plate Check and Adjustment."

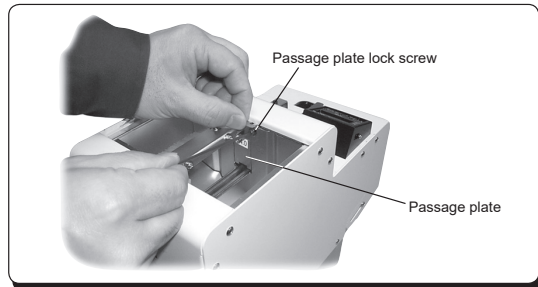
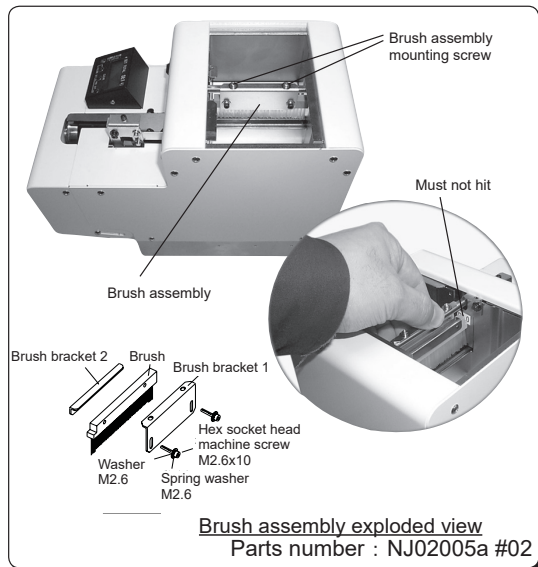

9.3 Replacing the Escaper Unit



CAUTION

Turn off the power switch before performing check and adjustment work.
When using screws of different nominal diameters, replace the passage paltes for both the rail assembly and the Escaper Unit.

- Remove two front cover mounting screws.
- Slide the front cover along the skewed groove on the side to a slanted position. Then, open the front cover downward.
- Remove the motor connector and the sensor connector.
- Remove the Escaper Unit mounting screw and then remove the Escaper Unit.
- To reassemble the Escaper Unit, reverse the removal procedure.
- The Escaper Unit requires positional adjustments in relation to the rail groove. See the instructions below.

9.4 Replacing the Rail Assembly



CAUTION

Turn off the power switch before performing check and adjustment work.
Eject all applied screws from inside this machine before proceeding with replacement work.

The rail assembly in this machine is easy to replace. The rail should require replacement if its rail groove is soiled or damaged to impair its performance.

When using screws of different nominal diameters, replace the passage plates for both the rail assembly and the Escaper Unit.

The rail assembly can be removed after the Escaper Unit has been removed.

- Loosen the Rail front-rear position lock screw and pull out the rail assembly to front.
- At reassembly, it is necessary to make positional adjustments with the tip of the rail and the escaper disc.
- Align the groove rail and the groove in the escaper disc with each other.
- Mount the Escaper Unit to keep the top surface of the groove in the escaper disc lower than the top surface of the rail groove.
- Turn on this machine and then make adjustments with the longitudinal position of the rail so its tip will not hit the escaper disc when the rail vibrates.

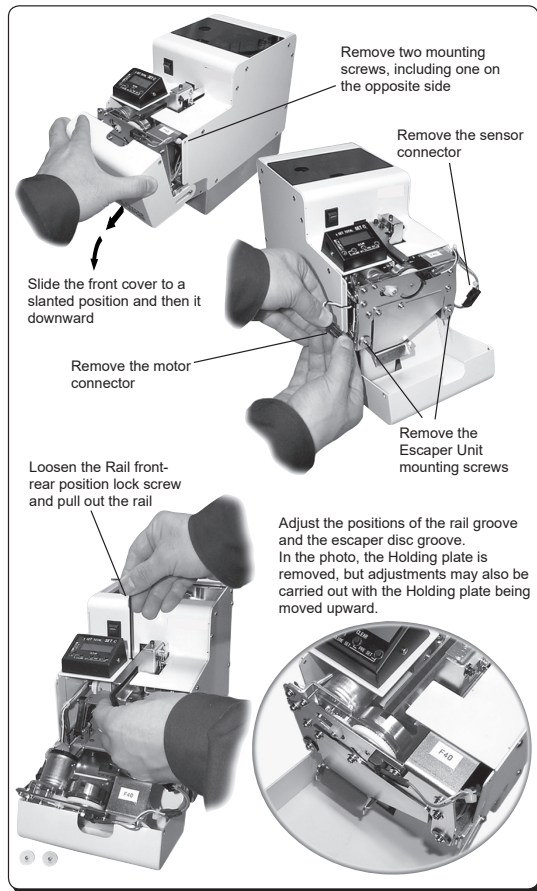

10. TROUBLESHOOTING



CAUTION Turn the power switch off before troubleshooting this machine.

Symptom	Cause	Action
8-1 This machine won't start when the power switch is turned on	<ul style="list-style-type: none">• Power is not connected.• Screws that have accumulated at the unloading port have not been unloaded for a certain period of time.• The unloading lever has not been pressed firmly.• Too many screws have been put in the Screw bin (overload protective circuit tripped).• Foreign matters (such as screws) have entered the inside of this machine (overload protective circuit tripped).• AC adapter failure	<ul style="list-style-type: none">• Check that AC adapter power connection.• Manipulate the unloading lever to unload screws from the unloading port.• Press the unloading lever firmly until it hits the stopper (LCD panel LED going out).• Adjust the Timer setting control screw.• Adjust amount of screws in the Screw bin.• Remove the foreign matters.• Contact your service agent or dealer.
8-2 Screws won't come flowing	<ul style="list-style-type: none">• Screws having a larger nominal diameter than specified have been loaded, or screws of different nominal diameters were present.• The supply of screws in the Screw bin has used up.	<ul style="list-style-type: none">• Use screws of the specified nominal diameter.• Remove the screws of the different nominal diameters.• Correct the supply of screws in the Screw bin.• Use of the NEJIKURA option is recommended.

Symptom	Cause	Action
<p>8-2 Screws won't come flowing</p>	<ul style="list-style-type: none"> • The brush cannot brush away screws in an abnormal posture. • The shank of a screw has entered the passage window. • Screws have been stopped in an unusual posture halfway in the rail. • The rail can't move longitudinally (due to screws stuck in rail gaps, for example). • Improperly adjusted timer setting control screw 	<ul style="list-style-type: none"> • Adjust the brush. Adjust the passage plate. Putting an appropriate supply of screws in the Screw bin could fix the problem. • Remove unusual screws and then adjust the passage plate. • Remove the screws in an unusual posture. Follow the instruction given below to remove screws. In doing so, be careful not to scratch the rail groove and other components. Loosen the bit guide assembly setscrew. Move up the Holding plate. Remove the screws in an unusual posture. Then, adjust the Holding plate position. • Remove the screws stuck in gaps. If no screws are stuck, contact our service to resolve the problem. • Adjust the timer setting control screw again.

Symptom	Cause	Action
<p>8-3 Screws have fallen into the rail groove</p>	<ul style="list-style-type: none"> • Screws having a smaller nominal diameter than specified have been loaded. • Screws having a shorter overall length than specified have been loaded. 	<ul style="list-style-type: none"> • Load screws of the specified nominal diameter. • Uncorrectable. • Consultation available on demand.
<p>8-4 Screws won't transfer smoothly on the rail</p>	<ul style="list-style-type: none"> • Narrow clearance between the Holding plate and the applied screw head • Screws with a spring washer one level smaller than the specified nominal diameter of the rail have been loaded. • Dust and oil have stuck on the rail. • The rail is not vibrating (due to screws stuck in rail gaps, for example). • Exhausted motor 	<ul style="list-style-type: none"> • Adjust the vertical position of the Holding plate. • Replace with a rail matched to the thread size. Replace with a escaper disc matched to the thread size. • Clean the rail. • Remove the screws stuck in rail gaps. If no screws are stuck , contact our service to resolve the problem. • Replace the motor.
<p>8-5 Screws in an unusual posture easily get through the passage window. Shanks easily enter the passage window.</p>	<ul style="list-style-type: none"> • Poorly adjusted passage plate • Too many screws have been put in the screw bin. 	<ul style="list-style-type: none"> • Re-Adjust the passage plate. • Correct the supply of screws in the screw bin.

Symptom	Cause	Action
<p>8-6 Screws cannot be unloaded at the unloading port</p>	<ul style="list-style-type: none"> • Screws have been arrested halfway in the rail. • Screws do not smoothly transfer from the rail to the escaper disc. 	<ul style="list-style-type: none"> • Adjust the Holding plate position. • Adjust the groove position of the rail and the escaper disc.
<p>8-7 This machine has halted abruptly.</p>	<ul style="list-style-type: none"> • The overload protective device has tripped. • Too many screws have been put in the Screw bin. • Screws have been stuck in rail gaps. • Screws have not been unloaded from the unloading port. • The unloading lever has not been pressed firmly. 	<ul style="list-style-type: none"> • Turn the power switch off, then back on. • Remove the overload. • Correct the supply of screws in the Screw bin. • Use of a NEJIKURA option is recommended. • Let our service handle the problem if this machine halts with a correct supply of screws. • Remove the screws stuck in gaps. • Manipulate the unloading lever to unload screws from the unloading port. • Press the unloading lever firmly until it hits the stopper (LCD panel LED going out).

Symptom	Cause	Action
<p>8-8 Scooping won't stop when a metered count of screws has been unloaded at the unloading port</p>	<ul style="list-style-type: none"> • Improperly adjusted Timer setting control screw 	<ul style="list-style-type: none"> • Adjust the Timer setting control screw.
<p>8-9 Screws have fallen into the inside this machine</p>	<ul style="list-style-type: none"> • The passage plate is too high • The holding plate is too high • The distance between the rail end and the escaper disc is too far. 	<ul style="list-style-type: none"> • Remove the cover and then the screw fallen inside. • Adjust the passage plate. • Adjust the holding plate. • Adjust the position between the rail end and the escaper disc.
<p>8-10 This machine gets noisier than before</p>	<ul style="list-style-type: none"> • Moving parts are undergreased. 	<ul style="list-style-type: none"> • Grease the moving parts of this machine. – Recommended type Macker : Dow Corning Asia CO.,LTD Model name: BR2Plus

11. SPECIFICATIONS

Exclusive adapter (Switching type)	Input : AC100~240V 50/60Hz Output : DC15V
Dimension	130W X 254D X 201H (mm)
Weight	Approx.6.0kgf
Screw capacity	150cc
A preset count	A preset count is up to 99. A preset count is limited by the screw size and the capacity of the unloading port.
Accessories	Operation manual x1 AC adapter x1 Allen wrench x1 Screwdriver x1 Ground wire x1
Installation location	Level stable place
Installation and storage condition	Temperature 0 ~ 40 °C Humidity 10 to 85% (without condensation)
Compliance standards	EMC: 2014/30/EU MD: 2006/42/EC RoHS: 2011/65/EU

Note:

- Check if the axis diameter of the loaded screw corresponds with the below rail groove width.
- With the range of screw size and lengths below, there may be instances if unique screw shape or structure not compatible with the screw feeder unit.
- Each model comes with a standard model-specific rail.
- Each model comes with a standard model-specific escaper disc.
- Each model comes with a standard model-specific passage plate.
- When changing the nominal diameter of a applied screw, replace the rail, escaper disc and passage plates in a set.
- The replacement rail assembly, Escaper Unit, and passage plates are options.
- The design, performance and specifications are subject to change without prior notice for the sake of improvement.
- The noise of this unit is less than LAeq 70 dB at a distance of 1 m.
- This product complies with EU directive. Please check the EU Declaration of Conformity for compliance standards.

Applicable Screw Reference Table						Screw head shape					
Screw nominal diameter	Screw shaft diameter (mm)	Screw head diameter (mm)	Washer diameter (mm)	Screw head height (mm)	Screw length (under head portion) (mm)	Pan head	Pan head			Bind	Counter-sunk
							Sems	Double sems	Washer head		
φ 3.0	2.8~3.1	4.0~5.5	4.0~8.0	1.0~5.5	4.8~25	○	○	○	○	○	○
φ 3.5	3.3~3.7	4.8~8.0	4.8~12.0	1.0~8.0	5.6~25	○	○	○	○	○	○
φ 4.0	3.8~4.1	5.4~8.0	5.4~12.0	1.0~8.0	6.4~25	○	○	○	○	○	○
φ 5.0	4.8~5.1	6.2~10.0	6.2~12.0	1.0~8.0	8.0~25	○	○	○	○	○	○
φ 6.0	5.8~6.2	7.2~12.0	7.2~12.0	1.0~8.0	9.6~25	○	○	○	○	○	○

※ Compatible with washer thickness 0.5 to 1.6mm.

Type	Model number	Screw nominal diameter	Exchange Kit number	Rail model number	Escaper Unit model number	Passage plate model number
FM-36	FM-3630	φ3.0	FR30SET	FR30	F30	W3630
	FM-3635	φ3.5	FR35SET	FR35	F35	W3635
	FM-3640	φ4.0	FR40SET	FR40	F40	W3640
	FM-3650	φ5.0	FR50SET	FR50	F50	W3650
	FM-3660	φ6.0	FR60SET	FR60	F60	W3660

-In the Exchange Kit ordered separately, Rail Assembly, Escaper disc Assembly, Passage plate are included.

- Please contact us by " ~ SET" type when you need rail.

○ Replacement parts

Rail Assembly

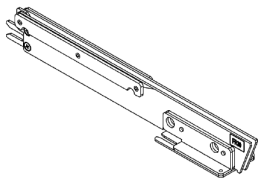

Escaper Unit

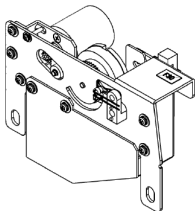

Passage plate

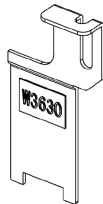

Drive motor Assembly : NJ04502

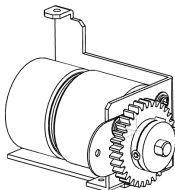

Main motor (With Harness)

: NJ09782 #10

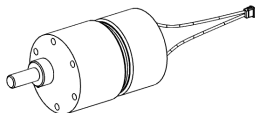

Brush Assembly: NJB0040

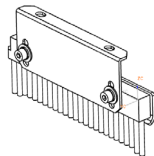

12.EXTERNAL DIMENTIONS

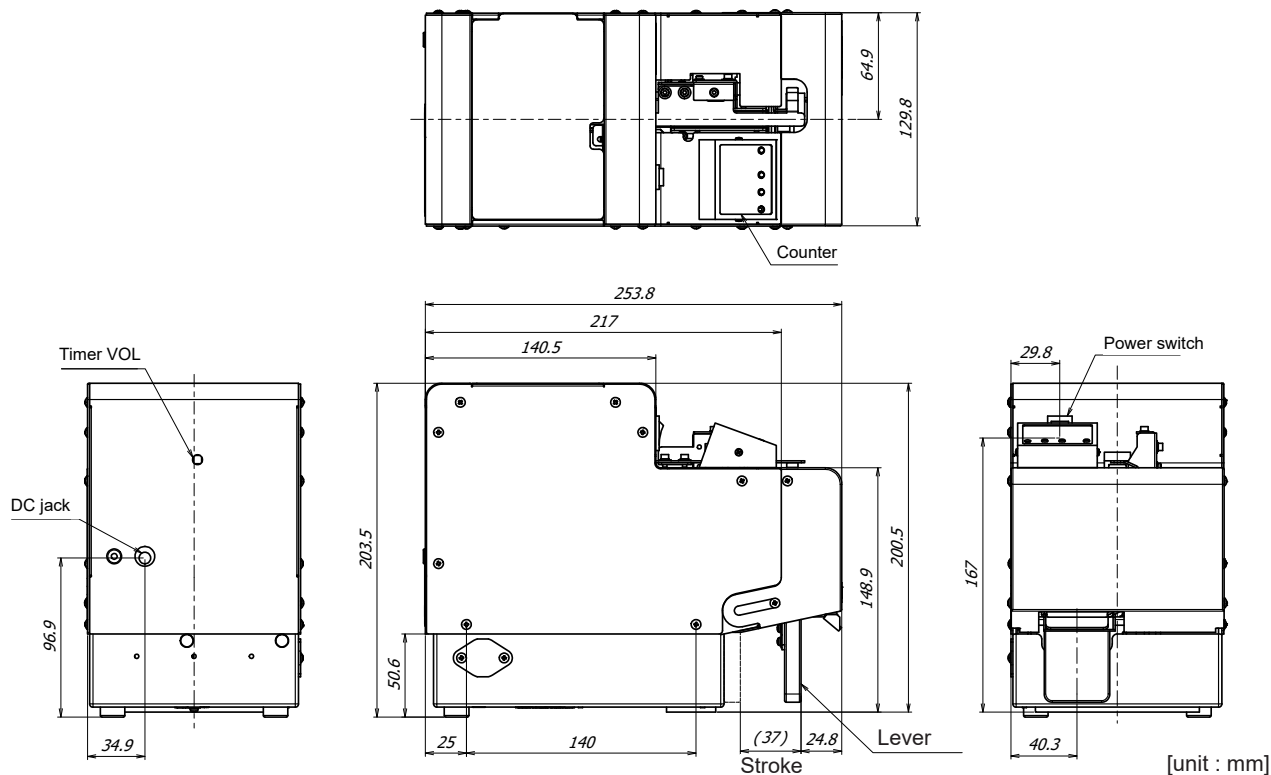

13. WARRANTY

For users within Japan, the product is warranted for a period of six months after the date of delivery. Such warranty will not be applicable to purchases or users outside of Japan. If any troubles should occur, however, contact your local dealer.

The solutions to the following situations may be implemented at a reasonable charge without regard to the warranty period.

1. Failure due to improper handling.
2. Failure due to product modification or improper processing.
3. Failure due to causes beyond control (for example earthquake or fire).
4. Failure attributable to any cause other than this product.
5. Consumables (brushes, main motor, escaper motor) and replaceable parts and replacement work expenses.

The repair parts shall be available within 5 years after purchase.

<http://www.ohtake-root.co.jp>

株式会社 大武・ルート工業

岩手県一関市萩荘字金ヶ崎 27 丁 021-0902

Tel +81-191-24-3144

Fax +81-191-24-3145

OHTAKE-ROOT KOGYO CO.,LTD.

27 Kanegasaki Hagisyou Ichinoseki

Iwate, 021-0902 JAPAN

Tel +81-191-24-3144

Fax +81-191-24-3145

「Quicher」 「OHTAKE」 「OHTAKE・ROOT KOGYO」 is a trademark or registered trademark of OHTAKE・ROOT KOGYO CO.,LTD.]
「Quicher(クイッチャー)」 「OHTAKE」 「OHTAKE・ROOT KOGYO」 は、株式会社 大武・ルート工業の商標又は登録商標です。

The specification and the design of a product may be changed without a preliminary announcement for improvement.
改良のため、予告なくデザイン、性能、仕様等を変更することがあります。

Photocopy, reproduction or publication of any part of this user's manual without permission, is strictly prohibited by copyright law.

この取扱説明書の一部または全部の無断転載、複製を禁じます。

(as of Apr. 2021)

© Copyright OHTAKE・ROOT KOGYO CO.,LTD.

(2021年4月現在)