

Automatic Screw Feeder

自動ネジ供給機

NSB Series

Operation Manual (Maintenance)

Read these instructions for the proper use of this machine.
After having read these instructions,
keep them in a convenient place so you
or the operator can refer to them whenever necessary.

ATTENTION : www.ohtake-root.co.jp is the only web site associated with our company.
We do not have any branches in China.

各位顾客请注意! : 「www.ohtake-root.co.jp 是敝司唯一的官方网站,
目前, 敝司在中国没有办事处与所谓的中国官网。」

注意! : www.ohtake-root.co.jp が当社唯一の HP アドレスです。
弊社の名を騙る偽サイトにご注意下さい。現在、当社は中国国内に支店はございません。

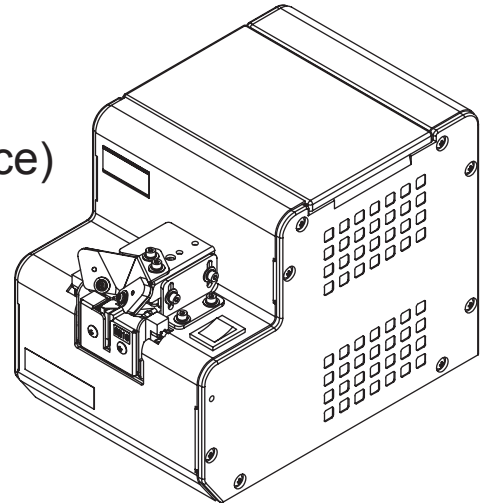

NSB1MA01Ma

CONTENTS

1. BEFORE USE	1
2. FOR SAFE USE	2
3. NAME OF MACHINE PARTS	3
4. ADJUSTMENTS AND CHECKS BEFORE USE	4
5. OPERATING INSTRUCTIONS	12
6. REPLACEMENT OF CONSUMABLE PARTS	13
7. TROUBLESHOOTING	18
8. SPECIFICATIONS	23
9. EXTERNAL DIMENSIONS	25
10. WARRANTY	26



Cautions

Be sure to follow the cautions, or it could lead to serious damage, such as injuries, electric shock, and damage to properties.

1) BEFORE USE

Thank you very much for selecting our Automatic Screw Feeder “NSB series”. Please check the following accessories before operating the machine.

- * Instruction manual, 1 copy
- * Passage plate, 2 pieces (1 piece is already attached to the main body.)
- * AC adapter, 1 piece
- * 0.35 mm gauge plate, 1 piece (used for adjusting the holding plate)
- * Hexagonal wrench, 1 piece
- * Screwdriver, 1 piece

※ For feeder machines purchased outside of Japan, no adaptor will be supplied with the feeder. Please purchase a separate adapter with equivalent output specification as required.

2) FOR SAFE USE

Read the following Cautions thoroughly for the safe use of this machine. Keep them in mind during the operation of the machine in order to prevent injuries and damage to property.

- Installation

 **Caution:** Install the machine on a level, stable location that can endure its weight and running conditions. If the machine falls down or turns over due to improper installation, injuries or property damage may occur.

- Operating Environment

 **Caution:** Do not operate this machine where flammable or corrosive gas is present. It is extremely dangerous to use this machine under such circumstances. Do not operate this machine in environment of high humidity.

- AC adapter

For feeder machines purchased outside of Japan, no adaptor will be supplied with the feeder. Please purchase separate adapter with equivalent output specification as required.

The transformer-type AC adapter attached to the machine has nominal output of DC12V-500mA; during application, it is designed to supply an average output at about 15V to the screw feeder.

In the case where a different type of adapter or external power source is used, it is recommended to use a 15V switching type adapter, or regulated power supply which can provide constant output at 15V.

- Rail

 **Caution:** Do not damage nor oil the rail.

- Screw compatibility

 **Caution:** Do not use screws with grease, dirty screws or any screw other than those prescribed.

- Access of screws

 **Caution:** Do not exert excessive or impactive force when accessing the screws.

- When machine is not in use

 **Caution:** Be sure to unplug the AC adapter from the wall outlet during closing hours and if the machine will be left unattended for any extended period of time.

- Abnormalities during operation

 **Caution:** Stop operation and unplug immediately whenever you sense abnormalities or unusual machine behaviors during the operation of this machine, such as a pungent odor. Turn off the power switch and disconnect the AC adapter from the receptacle. Continued operation may cause fire, electric shock, malfunction or personal injury. Immediately contact the dealer from which you purchased the product.

- Servicing

 **Caution:** Do not attempt to repair, disassemble or modify this machine except where specified by this manual. Consult your dealer for service and repair of this machine.

3) NAMES OF MACHINE PARTS

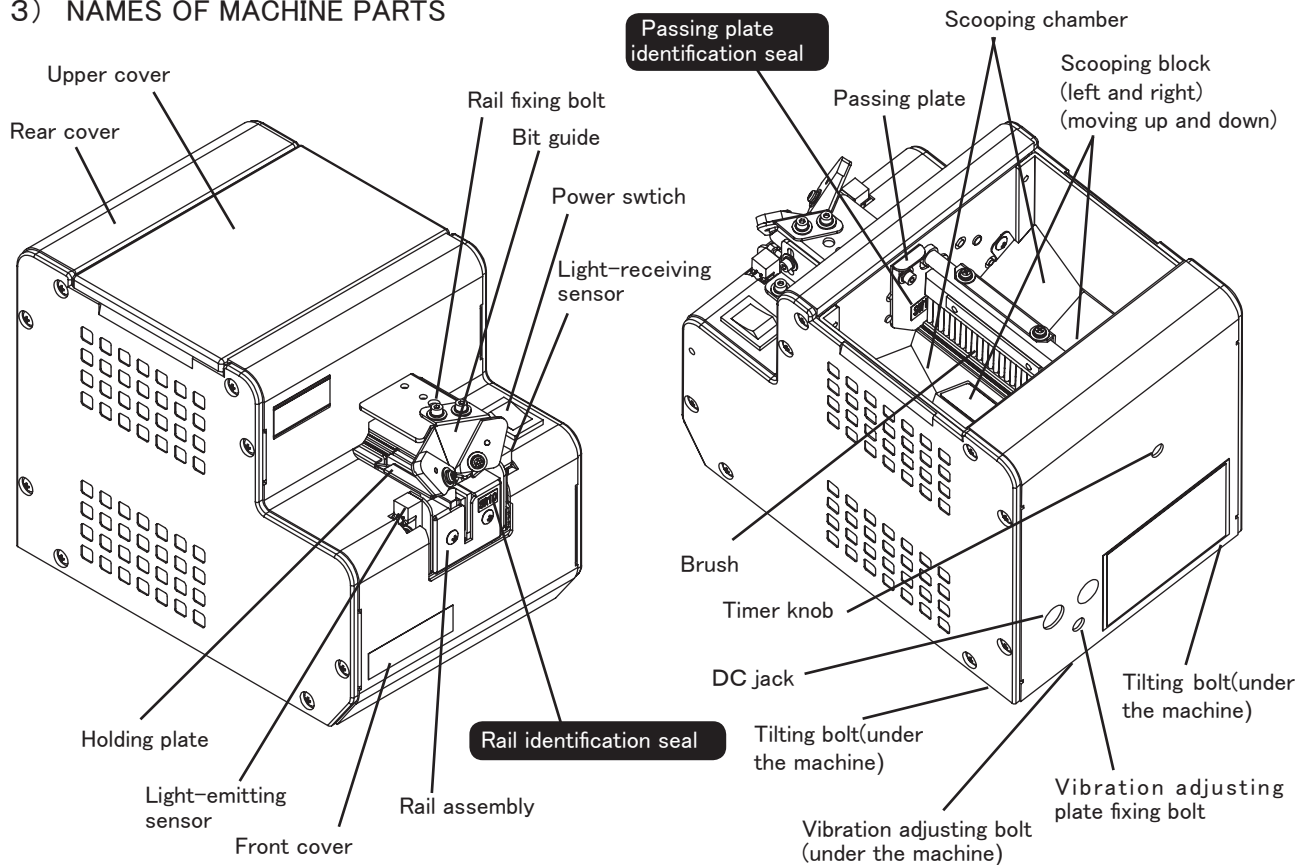

4) ADJUSTMENTS AND CHECKS BEFORE USE

Before using the machine, please check if the rail and components installed on the machine is suitable for the screw applied. The rail is ϕ 1.0 to ϕ 3.0 depending on the nominal diameter. It is determined by the identification seal on a rail front cover. There are two kinds of passage plates, namely one for ϕ 1.0 to ϕ 1.7 and one for ϕ 2.0 to ϕ 3.0. It is determined by a identification seal affixed on a passage plate.

Screw feeder series	Screw feeder model	Screw size	Rail model No.	Passing plate model No.
NSB	NSB10	ϕ 1.0	SR10	SW1017
	NSB12	ϕ 1.2	SR12	
	NSB14	ϕ 1.4	SR14	
	NSB17	ϕ 1.7	SR17	
	NSB20	ϕ 2.0	SR20	SW2030
	NSB23	ϕ 2.3	SR23	
	NSB26	ϕ 2.6	SR26	
	NSB30	ϕ 3.0	SR30	

◆ When there is no rail installed on the machine, please install the rail before use.

- First, unfasten the rail fixing bolt through the upper bit guide holder
- Insert the rail into the furthest point
- Fasten the fixing bolt

Quantity of screws thrown in

If too many screws are thrown in, orientation and transfer of the screws will be seriously affected. See the diagram on the right for the maximum number of throw screws in the [scooping chamber].

* Set the [scooping block] in the lowest possible position.

* Throw in screws up to a position of 2 mm to 3 mm below the rail groove face.

* In this condition, ensure that the front inclined-face of the ramp is not hidden by the screws.

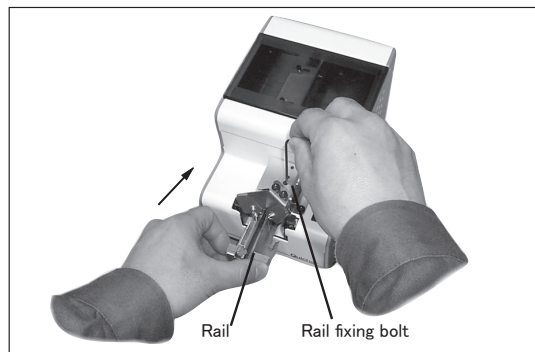

Ensure that the rail groove face is not hidden by the screws. (Screws should be positioned 2 to 3 mm below the rail groove.)



These parts of the inclined face of the ramp should be use underline.

◆ Adjustment of the brush

Check the height of the brush.

* As in the picture on the right, set the brush to an approximately level position.

* Ensure that the edge of the brush is grazing the screw's head.

* If the height of the brush is either too low or too high, orientation and transfer of the screws will be seriously affected.

* If adjustment is necessary, adjust it by loosening the brush height adjusting screw.

Note: Always unplug the AC adapter from the wall outlet before making any adjustments to avoid injury.

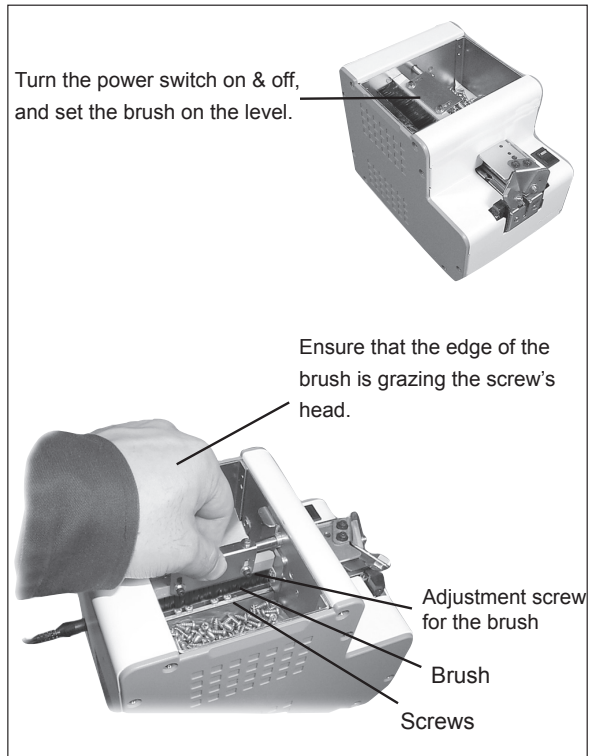

◆ Adjustment of the holding plate

Check the position of the holding plate.

* Ensure that the gap between the head of the used screw in the rail groove and the holding plate is approximately 0.2 mm to 1 mm.

* If there is no gap, the screw gets caught. If the gap is too large, the screw overlaps or juts out.

* If adjustment is necessary, adjust it up or down by loosening the bit guide bracket attaching screw.

◆ Easily adjust it by using the 0.35 mm gauge plate.

* Loosen the bit guide bracket attaching screw. Insert the gauge between screws on the rail and the holding plate. Tighten the bit guide bracket attaching screw when the holding plate is touching the front and the back of the gauge equally.

⚠ Caution: Matching the center of the holding plate outlet and the rail center may be necessary.

* Ensure that the center of the holding plate outlet matches the rail center.

* If not, adjust it by loosening the attaching screw.

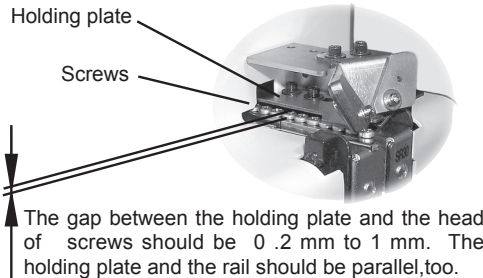

The bit guide bracket attaching screws

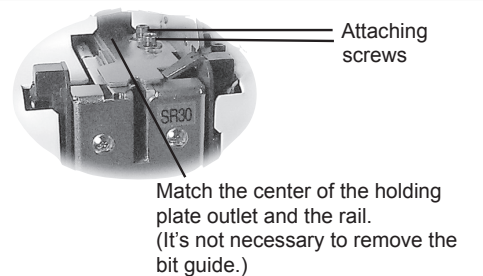
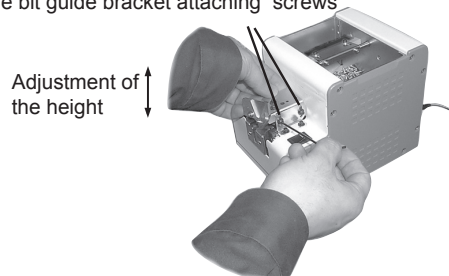

◆ Adjustment of the passage plate

Check the height of the passage plate.

* Ensure that the passage plate is adjusted at a height where the used screw can manage to pass.

* If the passage plate is too low, the screw cannot pass, and if too high, the screw easily gets caught.

* If adjustment is necessary, adjust it by loosening the passage plate attaching screw.

⚠ Caution: Slide the half blankings at both sides of the passage plate up and down the guide.

◆ Adjustment of the rail

Check the physical relationship of the stopper and sensor.

* Ensure that the rail is fixed so that “A” portion of the stopper is 0 mm to 0.5 mm ahead of the sensor optical axis.

* If adjustment is necessary, adjust it's location by loosening the rail attaching screw.

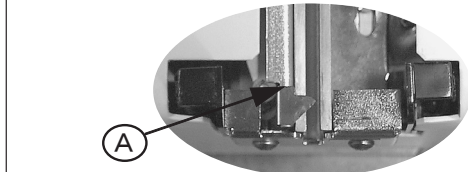
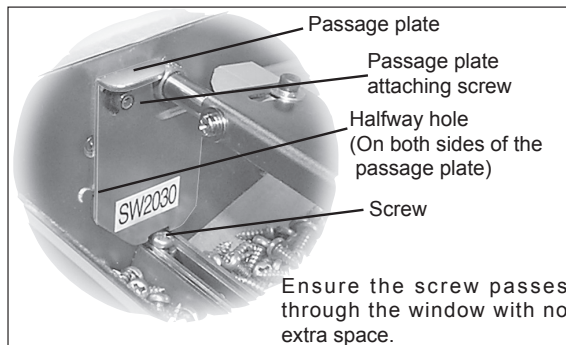

Looking down from the top, a portion of the stopper is sticking out 0 to 0.5 mm more forward than the sensor's optical axis. (It's not necessary to remove the bit guide.)

Loosen the rail attaching screw.

Adjust the rail back and forth.

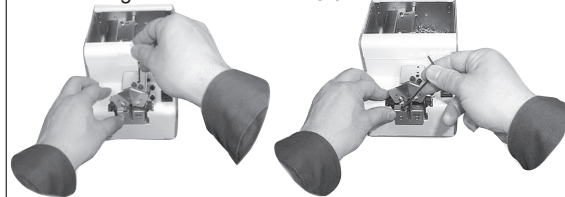

◆ Check/adjustment of the bit guide

Check the position of the bit guide.

* Adjust the bit guide to a position where a user can easily take screws.

Actually pick up screws a few times to adjust it.

Adjust it by loosening the attaching screws.

⚠ Caution: The rail is adjusted according to the physical relationship with the sensor as on the preceding page, so basically the rail is not adjusted here.

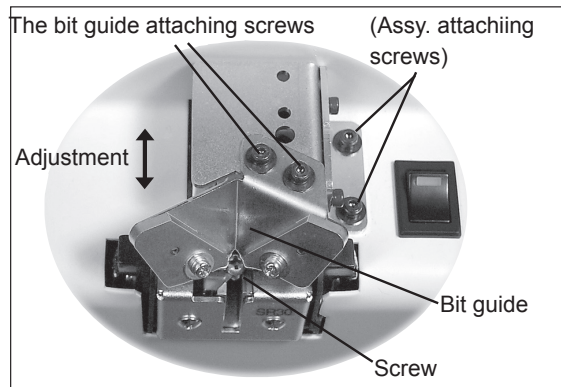

◆ Adjustment of the left and right guide pieces

Please check and adjust position of the guide piece as necessary.

The bit guide is originally set at approximately 3mm at the front opening, and shall be adjusted as needed by the user.

- Unfasten the front fixing screws, insert driver-bit to be used and adjust the slit opening, so that the bit can move freely.

- After the adjustment, try to pick up a screw and check its working condition before turning on the power.

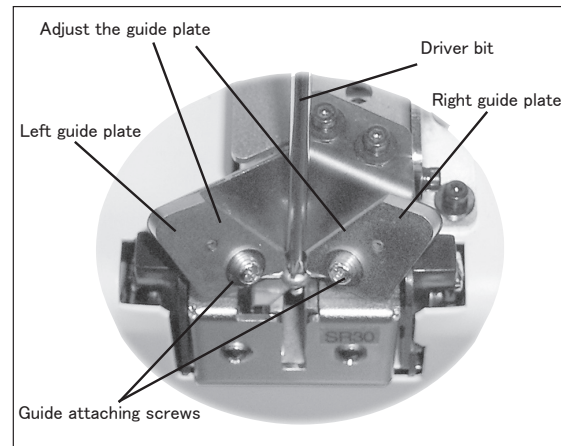

◆ Check/adjustment of rail vibration

Transfer speeds of screws differ according to screw type.

This machine can change rail amplitude and adjust the transfer speed.

* To adjust amplitude, loosen an amplitude fixing screw at the rear of this machine and turn the amplitude adjusting screw at the bottom of the machine.

Viewing it from the bottom, if turned clockwise, the amplitude becomes larger, and if turned counterclockwise, the amplitude becomes smaller.

* If you make the amplitude too large in order to speed up the transfer, it may become difficult to pull up screws. So, adjust it to appropriate amplitude for the type of screw being used.

* After adjustment is completed, be sure to tighten the amplitude fixing screw on the rear of the machine.

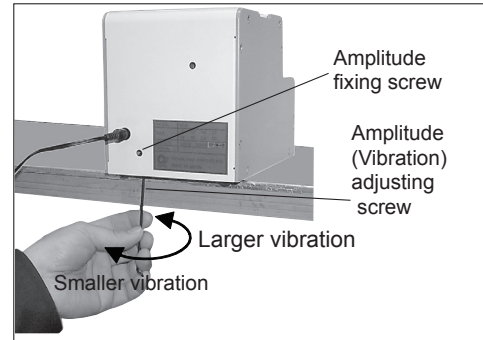

◆ Adjustment of the tilting bolts

- As the original setting, the automatic screw feeder shall be horizontal when set on a surface.

Depending on specific type of screw applied, there may be cases that the screws cannot move smoothly. At such instance, please check the "Adjustment of the rail" section listed in this operation booklet, or adjust tilting angle of the machine as necessary:

- The tilting bolts are located on bottom rear end of the machine.
- When these bolts are used, they shall be set at the same height and angle on both sides.
- Since the bolts do not have stoppers equipped inside, please be careful not to detach them from the machine body.
- After the adjustment, please verify if screw delivery functions properly before application.

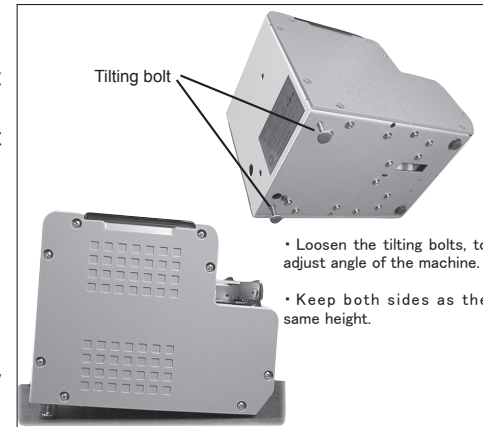

◆ Check of the sensor's optical axis

If there is no screw at the stopper section, this machine continues operation, and if there are screws, it stops after a certain period of time has passed. This machine has the level of the screw/no screw sensor adjusted by the reference rail on shipment. In reality, however, a level adjustment of the sensor may become necessary when using thin-head screws or due to occurrence of variation on rail replacement. Then, follow the directions (1) and (2) for the adjustment.

(1)

- Loose the sensor attaching screw on the side lit up as much as it moves by picking up the sensor holder with fingers, and turn on the power switch.
- Place a screw on the fail within the sensor range.
- Hold the rail end lightly with fingers as much as it doesn't vibrate so that screws doesn't pass through.
- When the sensor holder is moved up and down, there is a position the sensor of the receiving light side defects a screw head and stops the vibration. Tight the sensor attaching screw at this position.
- Comfirm whether it really works or not. See if a screw passes through and the sensor detects if and stops.

(2)

* Remove the machine body rear cover, and measure the voltage level. Adjust the IC4050 7th-pin voltage level. The ground, when measuring it, is the body's metal part.

* Adjustment is not necessary if the voltage level is within 0.25 to 1.5V when a rail is and if there is no screw at the stopper section.

* When adjustment is necessary, loosen the sensor attaching screw on the side. Adjust the voltage level by moving it up and down.

(It is easier to make an adjustment if connector of the main motor is removed.)

* After the adjustment, throw in the screws and run it practically in order to check the operation.

Note: When no loaded screws are: 0.25 V to 1.5 V

When loaded screws are: 3.5 V or more

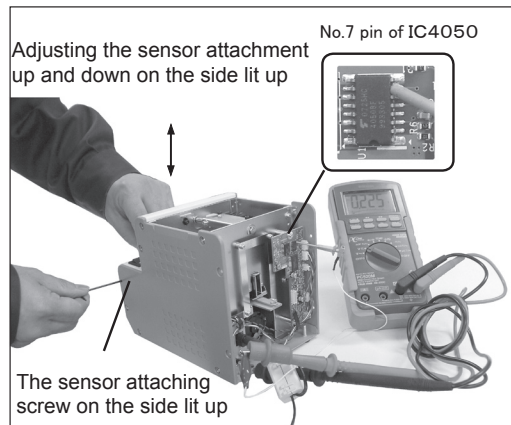

◆ Adjustment and Check of the timer

he speed of screw delivery depends on the actual kind of screw. By adjusting the timer of the machine the screws are picked up smoothly.

* If a screw is picked up on the stopper and the screw coming next is not picked up for a certain amount of time, the unit stops the operation. Then if you pick up the screw, it starts operating again. You can change the time by adjusting the timer within 1 to 6 seconds.

* Time changes after adjusting the times setting volume on the rear of the machine as shown on the right. Viewing the unit from the back, if it's turned clockwise, the time becomes longer, and if it's turned counterclockwise, the time becomes shorter.

* Do not use excessive force while making an adjustment. Turn it only as much as the possible rotating range allows.

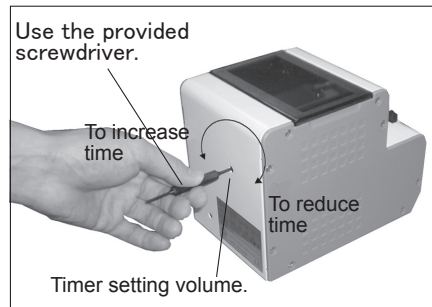

⚠ Caution : Use the screwdriver provided with the machine.
Using other screwdrivers may damage circuit components.

◆ The operation check of the overload protection circuit

For overload detection and check of protection circuits:

Try to force the movement of the scooping block to stop, to check the operation of overload detection and overload protection circuits.

If you force the movement of the scooping block to stop for about 4.5 seconds or less, the main motor stops after repeating rotations of reverse -> forward -> reverse ->

To cancel the above operational check, turn off and then turn on the power switch again.

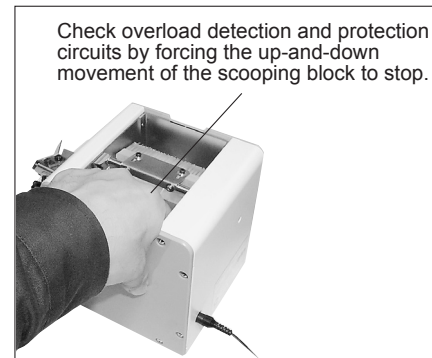

5) OPERATING INSTRUCTIONS

◆ Supplying screws (Refer to P. 4)

* Set the [scooping block] to the lowest possible position. Remove the top cover of the [scooping chamber]. Throw in screws up to a position of 2 mm to 3 mm below the rail groove top face.

* In this condition, ensure that the front inclined-face of the ramp is not hidden by the screws.

 **Caution:** An excessive quantity of screws thrown in may cause a machine malfunction.

◆ Switch-on

* Plug the provided AC adapter into a wall outlet and into the machine.

* Turn on the power switch. The power switch lamp will light up.

* The up-and-down movement of the scooping block and back-and-forth movement of the rail will activate.

* Subsequently, screws are successively sent to the outlet direction. Unless you pick up the screws in the stopper section, the sensor senses it and the machine stops operation.

* If you pick up the screws in the stopper section, the sensor senses it and the machine resumes operation.

◆ Picking up screws

* When picking screws up, use a bit that fits the screw diameter and groove width of the holding plate.

* Make a motor-driven driver's bit upright, put it down to the vertical direction along the V groove of the bit guide while turning it, and pull it out toward yourself when cross recess on the screw head is pick up by the bit.

 **Caution:** Do not exert any excessive force to the rail at this time. It may cause the machine to malfunction.

◆ Timer settings (Refer to P. 11)

* If you pick up screws of the stopper section and then do not pull up the next screws for a certain period of time, the machine stops. Operation will resume again after you pick up screws.

* The time until the machine stops is adjustable within 1 to 6 seconds. Adjust it according to the procedure in the diagram on the right.

 **Caution:** Always unplug the AC adapter from the wall outlet before making any adjustments to avoid injury.

6) REPLACEMENT OF CONSUMABLE PARTS

◆ Replacement of brushes

* If the tip of the brush wears out and does not wipe off a screw from an abnormal position, replace it with a new brush.

* Turn the machine's power switch on and off and position the brush as in the diagram on the right.

(Position it so that the Brush assembly mounting screws can be easily removed.)

* After reassembly, ensure that the brush and the passage plate do not clash when the Brush assembly moves. The gap is ideally "0".

* Refer to P. 4, "Check/adjustment of the brush" for mounting adjustments.

Part number of brush assembly:

NSB02053 #01 ⇒ standard part

NSB02053 #02 ⇒ optional part (more bristly)

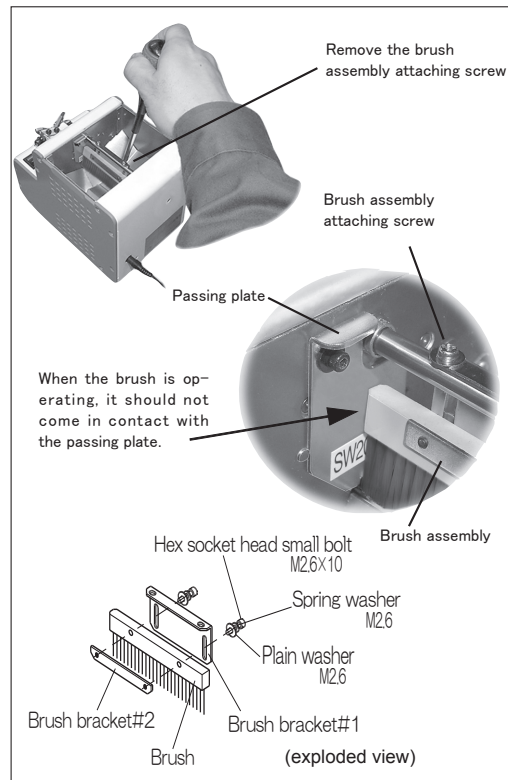

◆ Replacement of the bit guide unit

Replace the holding plate when there is difficulty in using it, such as after excessive wear.

When replacing the holding plate, remove the bit guide section off the body to prevent a mounting screw from falling inside the body.

* As in the diagram on the right, remove the bit guide section and replace the holding plate.

* Refer to P. 5, "Check/adjustment of the holding plate" for mounting adjustments.

Part number of bit guide unit:

NSB06003

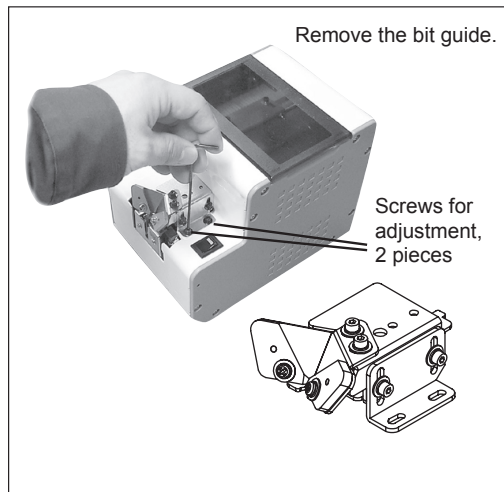

◆ Replacement of the bit guide assembly

Replace the bit guide when there is difficulty in using it, such as after excessive wear.

* As in the diagram on the right, remove the mounting screws and replace it.

* Refer to P. 7, "Check/adjustment of the bit guide" for mounting adjustments.

Part number of bit guide assembly:

NSB06002

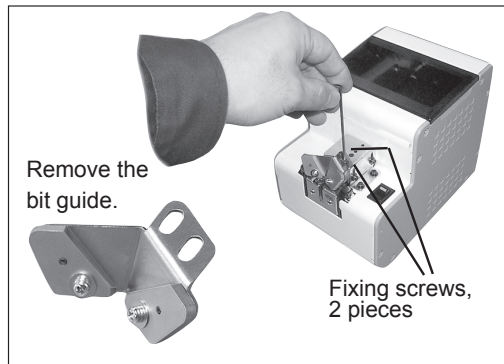

◆ Replacement of the stopper

Replace the stopper when there is difficulty in using it, such as after excessive wear.

* As in the diagram on the right, loosen the rail fixing screws and pull out the rail from the body.

* The stopper can be changed as in the diagram on the right.

* There are three types of stoppers.

* Be careful to correctly match the new stopper to the nominal diameter being used.

Determine the type of stopper by examining the hole of the mounting section.

Part number of stoppers:

ϕ 1.0(M1.0) ⇒ NSB05113

ϕ 1.2- ϕ 1.4(M1.4) ⇒ NSB05114

ϕ 1.7- ϕ 3.0(M3.0) ⇒ NSB05115

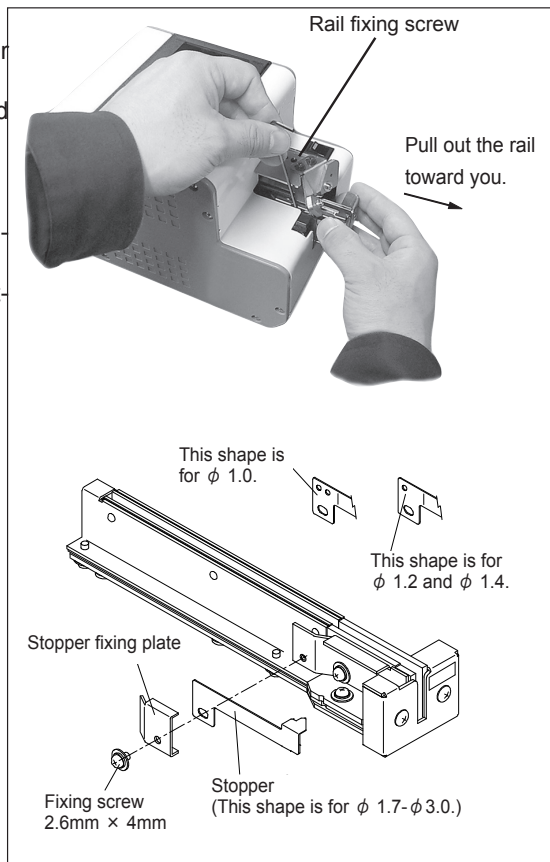

◆ Replacement of the main motor unit

Replace the motor after it is damaged.

* Remove the cover from the body.

(During removal, as in the diagram on the right, the cover mounting screws should be removed together with the front cover, leaving the four screws of the rear in place.)

* Remove the motor trunk connector.

* Remove the motor mounting screws on the motor's bottom face.

* Pull out the motor section from the rear of the body.

(To facilitate removal, insert a hexagonal wrench or the like into the long hole of the body base and push the motor mounting bracket backward.)

* Be careful not to break motor wires by using overly excessive force.

⚠ Caution: Unplug the AC adapter from the wall outlet before disassembly of the motor section.

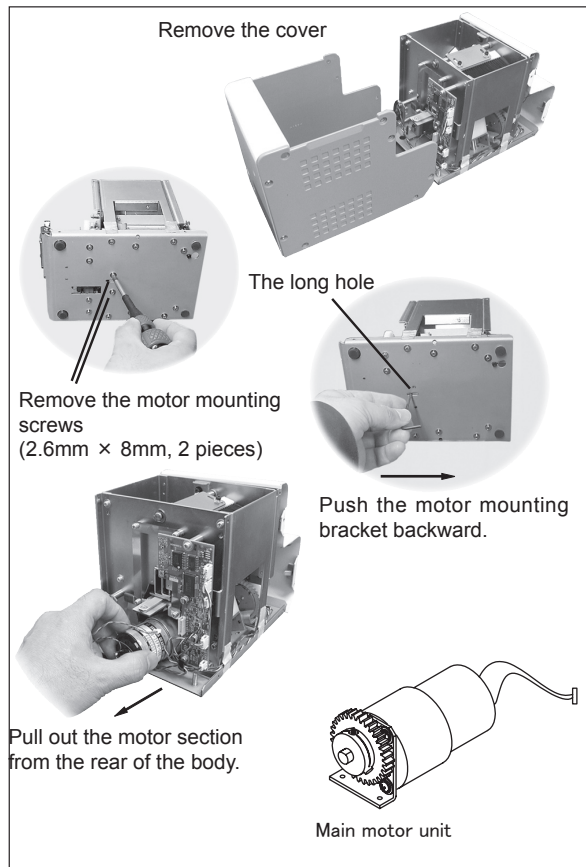

◆ Movement timing when replacing a motor

* To time a movement of the [scooping block] and that of a brush, the gears must be in mesh.

* If only the motor section is removed from the body, the movements can be timed by reassembling the motor section according to the timing in the diagram on the right.

* If it is difficult to mesh the driving gear of the motor section with the right and left trailing gears. Assembly can be made easier by loosening the mounting of the right driving shaft bracket (see the diagram on the right). Be sure to refasten the loosened screws after mounting the motor section.

* After mounting, start the motor and check the movement timing. (The right and left [scooping blocks] must move up and down almost simultaneously.)

* After checking the movement, refer to the wiring diagram and properly position the wiring.

(Avoid wires being caught when mounting the cover and be careful not to break motor wires by using overly excessive force.)

⚠ Caution: Unplug the AC adapter from the wall outlet before disassembly of the motor section.

Part number of main motor unit:
NSB03056

Drop [scooping block] on the right and left
as much as possible.

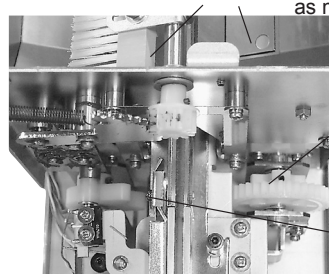

The pin is
approximately
vertical.

The pin is
approximately
inclined 46
degrees.

* Assemble the motor when [scooping block] is on the right and left as much as possible.

* In order to make the height of [scooping block] on the right and left just about the same, the driving gear attached to the motor axis and the sub-driving gear on the right and left must be in mesh. Then, tighten the screws (8mm×8, 2 pieces) for the motor bracket.

When the gears do not fit:

Loosen the following screws and free the driving shaft bracket, and it makes the gear easier to be in mesh.

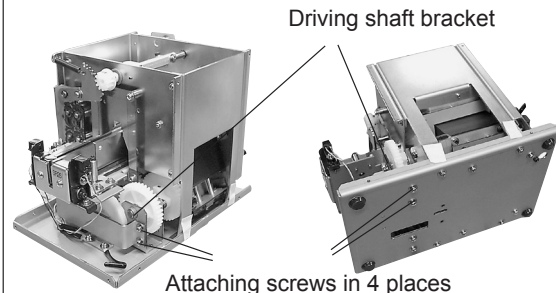

Driving shaft bracket

Attaching screws in 4 places

7) TROUBLESHOOTING (Please check the following before asking for a repair.)



Caution: Unplug the AC adapter from the wall outlet before and while making any adjustments to avoid injury or machine malfunction.

Trouble	Cause	Measures
<p>7-1 The machine does not operate though the switch has been turned on.</p>	<ul style="list-style-type: none"> * Power is not supplied. * Screws in the stopper section have not been taken away for a certain period of time. * Excessive quantity of screws is placed in the [scooping chamber]. * A foreign object (for example: a screw) intruded into the main body. * The AC adapter is faulty. 	<ul style="list-style-type: none"> * Confirm the power supply connection of the AC adapter. * Take away the screws in the stopper section. * Adjust the timer setting volume. * Adjust the number of screws in the [scooping chamber]. * Remove the foreign object. * Consult your dealer. [model number: UI315-15]
<p>7-2 Screws do not feed.</p>	<ul style="list-style-type: none"> * Screws of a larger nominal diameter than that prescribed for Rail Assembly are being used. * The quantity of screws in the [scooping chamber] has become too small. * The abnormally positioned screws are not completely removed by the brush on the passage plate. 	<ul style="list-style-type: none"> * Use the screws of the prescribed nominal diameter. * Remove abnormal screws. * Place adequate quantity of screws in the [scooping chamber]. * Adjust the brush. Adjust the passage plate. The situation may improve by placing adequate number of screws in the [scooping chamber].

Trouble	Cause	Measures
<p>7-2 Screws do not feed.</p>	<p>* A shank of a screw is caught in the passage plate.</p> <p>* A screw has stopped in an abnormal position in the middle of the rail.</p> <p>* The rail is not moving back and forth (screws are caught in a gap).</p>	<p>* Remove abnormal screws. Next, adjust the passage plate.</p> <p>* Remove the screw in an abnormal position. Remove it as follows: Loosen the Bit Guide Assembly fixing screws. Move the bit guide upwards. Incline the machine and remove the screw in an abnormal position from the rail tip. Next, adjust the holding plate.</p> <p>* Remove the screws stuck in the gap. If none are stuck, call for repair service.</p>
<p>7-3 Screws have dropped into the rail groove.</p>	<p>* Screws of a smaller nominal diameter than that prescribed for the Rail Assembly have been put in.</p> <p>* The gap between the holding plate and the screw head is too small.</p>	<p>* Use the screws of the prescribed nominal diameter.</p> <p>* If the problem is not solved, please call your distributor.</p>

Trouble	Cause	Measures
<p>7-4 The screws on the rail are not feeding smoothly.</p>	<ul style="list-style-type: none"> * The gap between the holding plate and the screw head is too small. * Screws with spring washer, of one rank lower in nominal diameter than that prescribed for the Rail Assembly are loaded. * The rail may be covered with dust or oil. * The rail doesn't move back and forth. (Screws are stuck in a gap.) * The motor may be damaged or worn out. 	<ul style="list-style-type: none"> * Adjust the bit guide assembly (together with the holding plate). * Run the machine on an incline. (If this does not solve the problem, please call your distributor.) * Clean the rail and rail guide. * Remove the screws stuck in the gap. * Replace the motor.
<p>7-5 The screws often run in an abnormal position through the passage plate.</p>	<ul style="list-style-type: none"> * Inadequate adjustment of the passage plate. * The machine is set front inclined downwards more than prescribed. 	<ul style="list-style-type: none"> * Adjust the passage plate. * Set it front inclined downwards within the prescribed value.

Trouble	Cause	Measures
<p>7-6 The screws often run in an abnormal position through the passage plate.</p>	<p>A screw has stopped in an abnormal position in the middle of the rail.</p> <p>* Adjustment of the front and back positions for Rail Assembly is incorrect.</p>	<p>* Adjust the bit guide and holding plate.</p> <p>* Adjust the Rail Assembly back and forth.</p>
<p>7-7 Screws are not feeding at the bit guide's outlet.</p>	<p>* The front and back positions are not on the right places.</p> <p>* The right and left positions are not on the right places.</p>	<p>* Adjust the Rail Assembly back and forth.</p> <p>* Adjust the bit guide and the holding plate.</p>
<p>7-8 The machine suddenly stops operation.</p>	<p>* Due to an overload, the over-current protection circuit has operated.</p> <p>* Too many screws are in the .</p> <p>* A screw is caught in the clearance.</p> <p>* A screw, at the extraction site, could not be extracted for an amount of time.</p>	<p>* Turn on the power switch again.</p> <p>* Remove the cause of overload.</p> <p>* Remove screws to a proper level.</p> <p>* If the problem is not solved, please call your distributor.</p> <p>* Remove the screw that is caught.</p> <p>* Remove the screw.</p>

Trouble	Cause	Measures
<p>7-9 A screw has dropped inside the machine.</p>		<p>* Shake off the screw from the hole on the back of the machine.</p>
<p>7-10 There are screws in the stopper section, but the machine does not stop operation.</p>	<p>* There's deviation of the rail and sensor positions. * If the positions are on the right places.</p>	<p>* Move the rail back and forth and adjust it in a position where the operation stops. * Adjust the sensor height.</p>
<p>7-11 If screws in the stopper section are taken out, but it does not perform the next operation.</p>	<p>* The sensor is not adjusted. * A wire connected to a sensor is snapped.</p>	<p>* Adjust the sensor height. * Fix it by soldering. * Replace sensor assembly.</p>
<p>7-12 The sound of the machine becomes louder.</p>	<p>* Grease has run out.</p>	<p>* Apply grease to the driving section. Recommended grease: BR2 Plus Dow Corning Asis Co.,Ltd</p>

8) SPECIFICATIONS

Power AC adapter (linear type)	Input: AC100V 50/60Hz Output: DC12V 500mA
Dimensions	123(W) × 181(D) × 145(H) (mm)
Weight	Approx. 2.9Kg (including rail)
Screw capacity	Approx. 80cc
Following accessories	Operation Manual 1 copy AC Adapter 1 unit Passing Plate 2 pieces (one is already installed.) Hexagonal Wrench 1 piece Screwdriver 1 piece 0.35 mm gauge plate 1 piece

[Caution]

- The transformer-type AC adapter attached to the machine has nominal output of DC12V-500mA; during application, it is designed to supply an average output at about 15V to the screw feeder. In the case where a different type of adapter or external power source is used, it is recommended to use a 15V switching type adapter, or regulated power supply which can provide constant output at 15V.
- For feeder machines purchased outside of Japan, no adaptor will be supplied with the feeder. Please purchase separate adapter with equivalent output specification as required.
- Check if the axis diameter of the loaded screw corresponds with the below rail groove width.
- With the range of screw size and lengths below, there may be instances if unique screw shape or structure not compatible with the screw feeder unit.
- In the main body type, the main body model can be changed.
- To change the nominal diameter of loaded screw, replace it with a part that is mentioned in the next page table.
- The rail and passing plate are separately available for replacement.
- The design, performance and specifications are subject to change without prior notice for the sake of improvement.

Reference table of the specified screws					Shape of screw head						
					Pan head			bind	Flat head	Counter sunk head	hexagon flange bolt
Screw size	Screw shaft diameter (φ)	Screw head diameter (φ)	Screw head thickness (mm)	Screw shaft length (mm)	Sems	Double sems	Washer head				
φ 1.0	0.9~0.95	1.2~4.5	0.35~1.0	1.6~10					○		
φ 1.2	1.1~1.15	1.4~4.5	0.35~1.0	1.8~10					○		
φ 1.4	1.3~1.4	1.7~4.5	0.35~1.0	2.0~10					○		
φ 1.7	1.6~1.7	2.0~4.5	0.35~1.0	2.3~10					○		
φ 2.0	1.9~2.1	2.4~6	0.35~4.5	2.6~20	○	○	○	○	○	○	○
φ 2.3	2.2~2.4	2.7~6	0.35~4.5	2.9~20	○	○	○	○	○	○	○
φ 2.6	2.5~2.7	3.0~6	0.35~4.5	3.2~20	○	○	○	○	○	○	○
φ 3.0	2.9~3.2	3.5~6	0.35~4.5	3.6~20	○	○	○	○	○	○	○

※ Compatible with washer diameter up to 9 mm, thickness 0.35 to 1.0mm.

Screw feeder series	Screw feeder model	Screw size	Rail model No.	Passing plate model No.
NSB	NSB10	φ 1.0	SR10	SW1017
	NSB12	φ 1.2	SR12	
	NSB14	φ 1.4	SR14	
	NSB17	φ 1.7	SR17	
	NSB20	φ 2.0	SR20	SW2030
	NSB23	φ 2.3	SR23	
	NSB26	φ 2.6	SR26	
	NSB30	φ 3.0	SR30	

○Replacement parts

• Rail

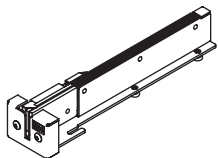

• Passing plate



• Brush assembly
NSB02053 #01

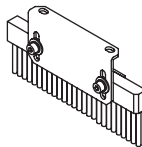

• Stopper

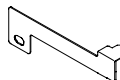

• Main motor unit
NSB03056

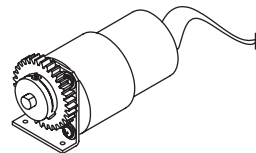

• Bit guide assembly
NSB06002

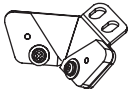

• Bit guide unit
NSB06003

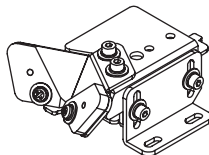

9) EXTERNAL DIMENSIONS

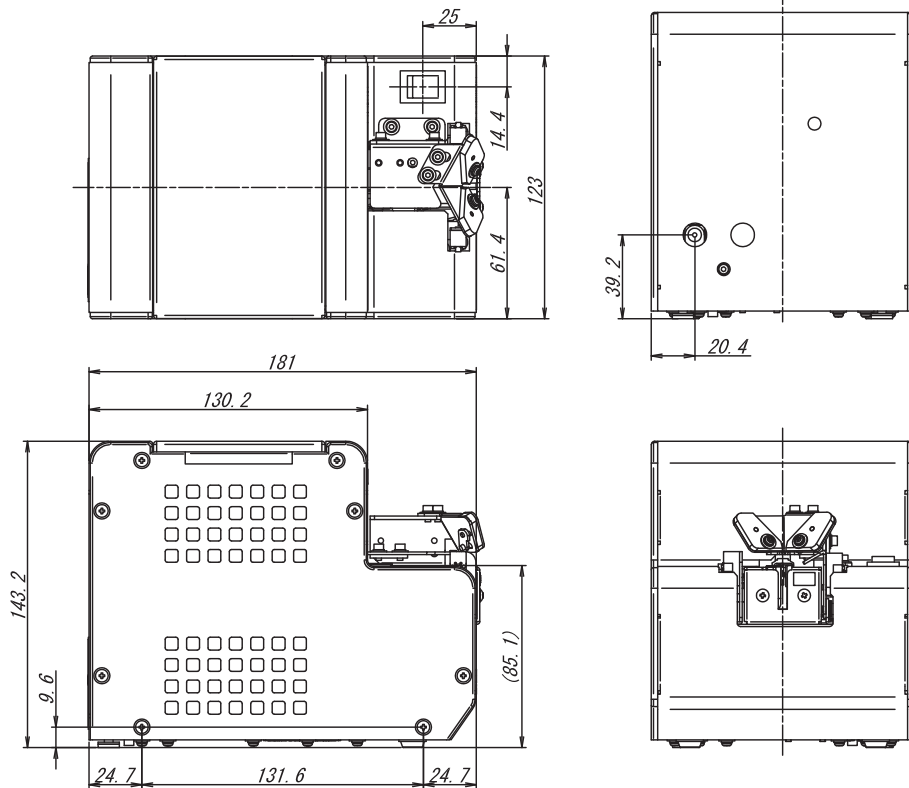

Unit : mm

10) WARRANTY

For users within Japan, the effective term of warranty is 6 months after delivery.

Such warranty will not be applicable to purchases or users outside of Japan.

If any troubles should occur, please contact your dealer.

After the warranty period, repair services will be completed.

In the following cases, the purchaser shall pay for parts and labor regardless of the terms of warranty:

- ① Failure due to improper handling.
- ② Failure due to product modification or improper processing.
- ③ Failure due to causes beyond control (for example earthquake or fire).
- ④ Failure attributable to any cause other than this product.
- ⑤ Consumables (brushes, bit guide, main motor, holding plate, stopper)
and replaceable parts and replacement work expenses.

The repair parts shall be available within 5 years after purchase.

<http://www.ohtake-root.co.jp>

株式会社 大武・ルート工業

岩手県一関市萩荘字金ヶ崎 27 〒 021-0902

Tel +81-191-24-3144

Fax +81-191-24-3145

OHTAKE-ROOT KOGYO CO.,LTD.

27 Kanegasaki Hagisho Ichinoseki

Iwate, 021-0902 JAPAN

Tel +81-191-24-3144

Fax +81-191-24-3145

「Quicher」「OHTAKE」「OHTAKE・ROOT KOGYO」are trademarks or/and registered trademarks of OHTAKE・ROOT KOGYO CO.LTD.]

「Quicher(クイッチャー)」「OHTAKE」「OHTAKE・ROOT KOGYO」は、株式会社 大武・ルート工業の商標又は登録商標です。

The specifications and/or design may be altered, without notice, whenever there are changes or improvements.

改良のため、予告なくデザイン、性能、仕様等を変更することがあります。

Photocopying, reproduction or publication, in whole or in part, of this manual, without permission, is strictly prohibited by copyright law.

この取扱説明書の一部または全部の無断転載、複製を禁じます。

(as of Oct. 2016)

© Copyright OHTAKE・ROOT KOGYO CO.,LTD.

(2016年10月現在)